

DPX / AS81659

527-142

Backshell, EMI TAG Ring, DPX4

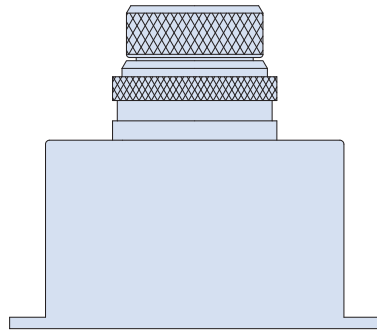

527-142

EMI TAG Ring® backshell fits DPX4 connectors

Fits ITT Cannon DPX4 connectors. Backshell has slotted ring, gold-plated ground spring and PTFE friction washer for terminating individual wire shields. Two strain relief options: saddle clamp or nut (nut requires shrink boot for cable strain relief).

Aluminum with stainless steel hardware. Gold-plated beryllium copper ground spring, PTFE friction washer.

TAG® RING

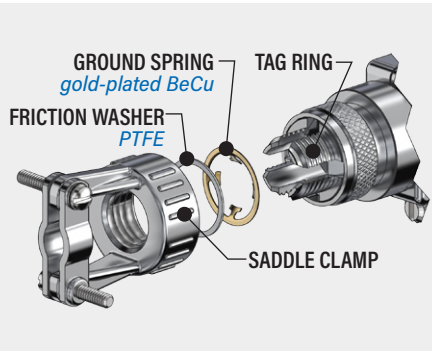

SHRINK BOOT

Optional lipped heatshrink boot fits .135 (3.4) wide boot groove. Type 1 high-performance semi-rigid elastomer resists fuels and oils and withstands temperature extremes. Operating temperature range -75 to +150 °C.



Part Number 770-001S108

PART NUMBER

Sample PN →		527-142	M	L	S
Base P/N	527-142				
Finish	M	Electroless Nickel			
	JF	Cadmium with Yellow Chromate			
	TZ	Tin-Zinc			
	NF	Olive Drab Cadmium			
Strain Relief	Omit	Nut			
	L	Saddle Clamp			
Entry Location	Omit	Top Entry			
	S	Side Entry			
Shrink Boot	Omit	None			
	S	Shrink Boot Included (770-001S108)			

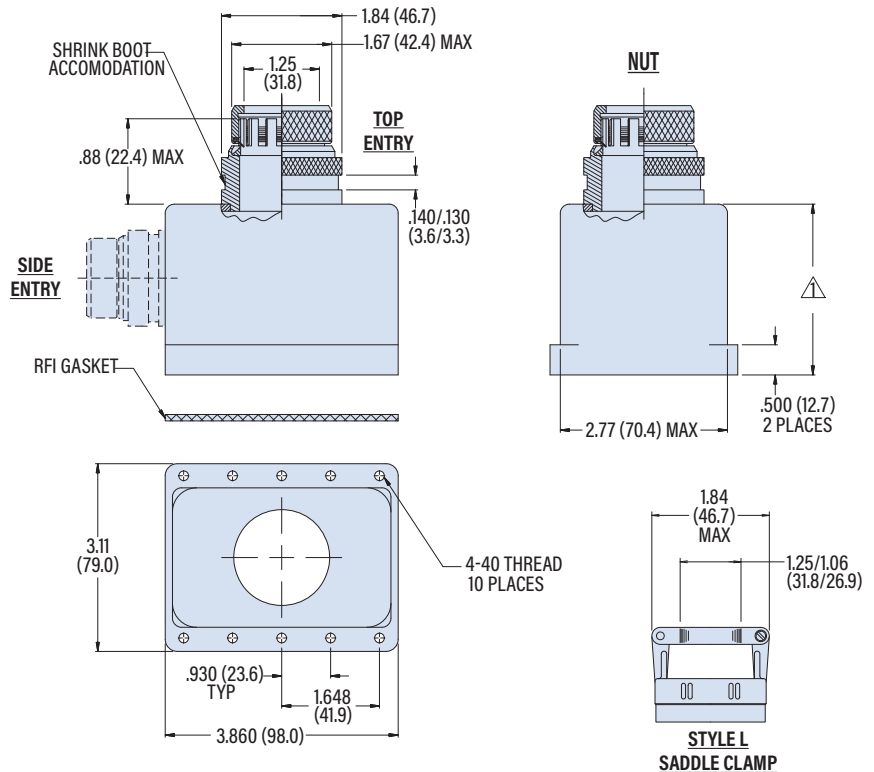

△ BACKSHELL HEIGHT TOP ENTRY IS 2.00 (50.8), SIDE ENTRY IS 2.50 (63.8)

DPX / AS81659 BACKSHELLS