

DPX / AS81659



527-476

Backshell, EMI Banding, AS81659/ DPXB

- Composite Split
- Band-Master ATS Shield Termination



527-476

Split EMI backshell fits AS81659 connectors

Lightweight composite material. Terminate cable braid shield to backshell with **Band-Master ATS®** banding strap. Options include slots for individual wire shields and Qwik-Ty arm .

Thermoplastic with stainless steel hardware and aluminum mesh/neoprene gasket.

FIGURE 1 POLYSULFIDE OPTION

TERMINATION AREAS
FREE OF CADMIUM

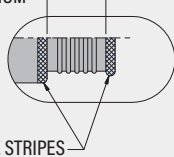

POLYSULFIDE STRIPES
POLYSULFIDE OPTION IS AVAILABLE
FOR FINISH CODE XW ONLY

BAND OPTIONS

Terminate cable braid to backshell with optional band strap and banding tool. Pre-coiled bands are passivated stainless steel. Slim Standard bands have reduced thickness for weight reduction.



Band Type and Width	Hand Tool	Pneumatic Tool
Standard: .24 (6.1)	601-100	601-106
Slim Standard: .24 (6.1)	601-109	601-110

PART NUMBER	
Sample PN →	527-476 XM S T K G
Base P/N	527-476
Finish	XM Electroless Nickel XW Olive Drab Cadmium
Connector Code	Omit All AS81659 Connectors except for Connector Code P1. Backshell Replaces Insert Retainer Plates. P1 DPX**E and Class E Environmental Connectors with Interfacial and Grommet Seal. Backshell Installs on Insert Retainer Plates.
Slot Option	Omit None S Slots Included
Qwik-Ty Option	Omit None T Qwik-Ty Strain Relief Arm Included
Band Option	Omit No Band K Standard Band Included J Slim Standard Band Included
Polysulfide Option	Omit None P Polysulfide Stripes (<i>Finish Code XW Only, fig. 1</i>)
EMI Gasket	Omit None G EMI Gasket Included

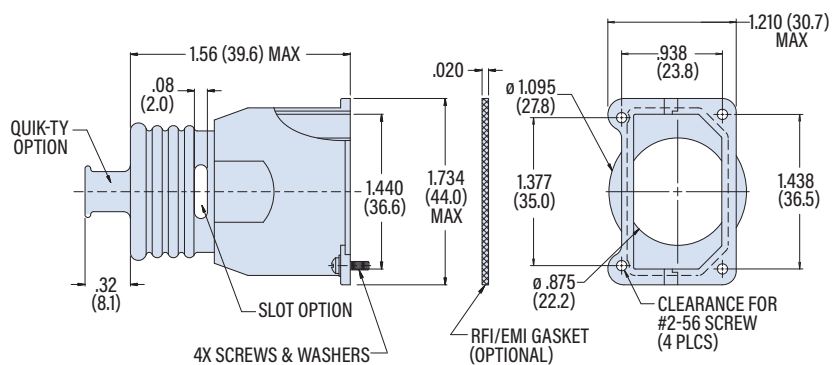

DPX / AS81659 BACKSHELLS