

BACKSHELLS AND ACCESSORIES FOR AS81703 SERIES 3 TYPE CONNECTORS 90° Environmental Backshell

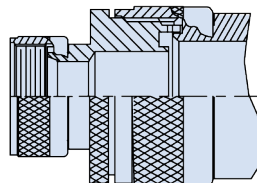

AS85049/9 and MS3188B

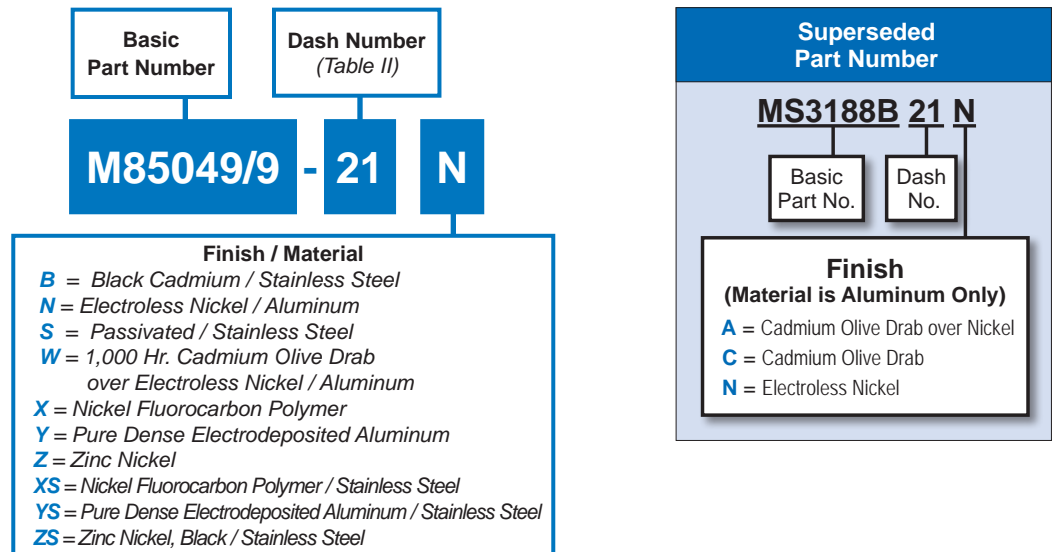

STYLE 2

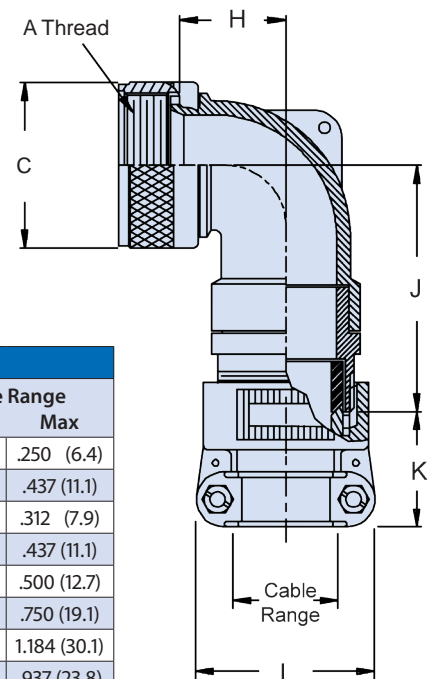

TABLE II: Dash Number and Cable Range

Dash No.	Shell Size	A Thread Ref	C Dia Max	H Max	J Max	K Ref.	L Max	Cable Range	
								Min	Max
1	03	9/16-24 UNEF	.98 (24.9)	.761 (19.3)	1.862 (47.3)	1.027 (26.1)	.957 (24.3)	.125 (3.2)	.250 (6.4)
2	03			1.511 (38.4)	1.382 (35.1)	1.027 (26.1)	1.145 (29.1)	.250 (6.4)	.437 (11.1)
6	12	7/8-20 UNEF	1.28 (32.5)	.766 (19.5)	2.002 (50.9)	1.027 (26.1)	.957 (24.3)	.125 (3.2)	.312 (7.9)
7	12			.766 (19.5)	2.002 (50.9)	1.027 (26.1)	1.145 (29.1)	.250 (6.4)	.437 (11.1)
8	12			.766 (19.5)	1.397 (35.5)	1.027 (26.1)	1.332 (33.8)	.350 (8.9)	.500 (12.7)
38	61			1.291 (32.8)	2.442 (62.0)	1.059 (26.9)	1.551 (39.4)	.500 (12.7)	.750 (19.1)
39	61	1-1/2-18 UNEF	1.89 (48.0)	1.291 (32.8)	2.087 (53.0)	1.375 (34.9)	2.113 (53.7)	.875 (22.2)	1.184 (30.1)
53	61			1.291 (32.8)	2.087 (53.0)	1.156 (29.4)	1.770 (45.0)	.625 (15.9)	.937 (23.8)

NOTES

1. For complete dimensions see the applicable Military Specification.
2. Metric dimensions (mm) are in parentheses.
3. When maximum cable entry is exceeded, Style 2 will be supplied.
4. Cable Range is defined as the accommodation range for the wire bundle or cable. Dimensions shown are not intended for inspection criteria.
5. Approximate chain lengths: Dash No. 01-12 = 5.0 (127.0); Dash No. 13-29 = 6.0 (152.4).