

MIL-DTL-38999 Series IV Type
234-205 Plug with wing-lock coupling

ENVIRONMENTAL CONNECTORS

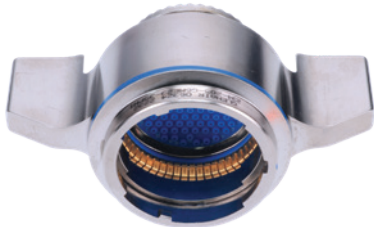

-1 standard wing nut

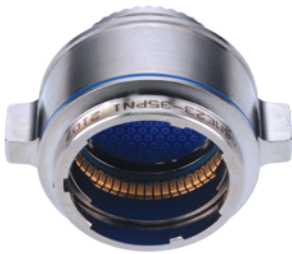

-2 low-profile wing nut

"BETTER-THAN-QPL" FEATURES AND BENEFITS

- Secure breech-lock mating connector meets D38999 shock and vibe
- Improved plug ground fingers deliver outstanding EMI performance—equal to D38999 Series III
- Glenair Signature Tin Zinc finish class is RoHS compliant and cadmium compatible
- Precision-machined key/keyway polarization for reliable mismatching protection
- Scoop-proof design prevents pin damage and short circuits
- Fully tooled for all MIL-STD-1560 insert arrangements
- Contact options include size #22D, #20, #16, and #12 (see High-Speed series for Size #8)
- 500 mating cycles exceeds MIL-DTL-38999 specification

HOW TO ORDER									
Sample Part Number	234-205	G6	NF	17	-8	P	N	2	
Basic Part Number	234-205								
Connector Style	G6 = Plug, EMI Spring								
Material/Finish	NF, MA, MT, ME, MN, TZ, ZR, Z1, ZL (See Table I)								
Connector Size	B, C, D, E, F, G, H, J								
Insert Arrangement	PER MIL-STD-1560								
Contact Style	(See Table II)								
Alternate Polarization	A, B, C, D, E, K, L, M, R, N = Normal								
Wing Nut Profile	1 = Standard 2 = Low Profile								

TABLE I - MATERIAL/FINISH			
Equiv Class	Sym	Material	Finish
W	NF	Aluminum Alloy	Cad/O.D. over Electroless Nickel
G*	MA**		Electroless Nickel, Matte
T*	MT		Nickel-PTFE
F	ME		Electroless Nickel
AA	MN		MegaNickel
V	TZ		Tin-Zinc
Z*	ZR		Zinc Ni, Black (Tri-Valent CR)
K*	Z1	Stainless Steel	Passivate
L*	ZL		Electrodeposited Nickel

* = Glenair Equivalent Only

** = Connectors for space applications must be ordered with "MA" finish and mod code "-186T" to conform to the thermal vacuum outgassing requirements of class G.

TABLE II - CONTACT STYLE		
Sym	Description	Contact P/N
P	Pin, Gold	M39029/58
S	Socket, Gold	M39029/56
A	Pin Insert, Less Pin Contacts	
B	Socket Insert, Less Socket Contacts	

MIL-DTL-38999 Series IV Type
234-205 Plug with wing-lock coupling

TABLE III -1 STANDARD WING-NUT PROFILE DIMENSIONS

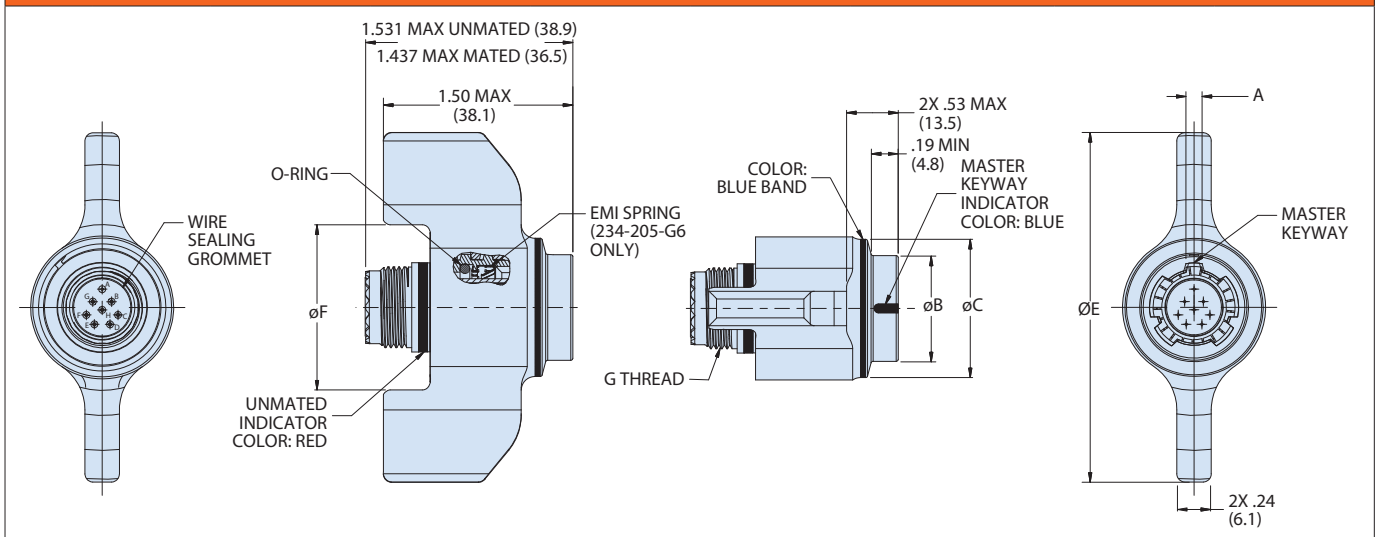

Shell Size	Shell Size Code	A		ØB Max	ØC Max	G Thread	ØE Max	ØF
		Socket	Pin					
11	B	.116 (2.95)	.076 (1.93)	.776 (19.7)	1.047 (26.6)	M15 X 1.0-6g 0.100R	2.540 (64.52)	1.200 (30.48)
13	C	.117 (2.97)	.077 (1.96)	.902 (22.9)	1.220 (31.0)	M18 X 1.0-6g 0.100R	2.690 (68.33)	1.340 (34.04)
15	D	.137 (3.48)	.097 (2.46)	1.039 (26.4)	1.346 (34.2)	M22 X 1.0-6g 0.100R	2.840 (72.14)	1.500 (38.10)
17	E			1.150 (29.2)	1.472 (37.4)	M25 X 1.0-6g 0.100R	2.940 (74.68)	1.600 (40.64)
19	F	.157 (3.99)	.117 (2.97)	1.276 (32.4)	1.583 (40.2)	M28 X 1.0-6g 0.100R	3.060 (77.72)	1.720 (43.69)
21	G			1.402 (35.6)	1.705 (43.3)	M31 X 1.0-6g 0.100R	3.190 (81.03)	1.720 (43.69)
23	H	.177 (4.50)	.137 (3.48)	1.528 (38.8)	1.831 (46.5)	M34 X 1.0-6g 0.100R	3.310 (84.07)	1.980 (50.29)
25	J			1.650 (41.9)	1.957 (49.7)	M37 X 1.0-6g 0.100R	3.440 (87.38)	2.100 (53.34)

NOTES

- Material/Finish:
 - Barrel, Coupling Nut - See Table I
 - Grounding Spring - BeCu Alloy / Nickel or Gold Plate
 - Insulator - High Grade Rigid Dielectric
 - Seals, Grommet - Fluorosilicone Blend
 - Contacts - Copper Alloy / See Table II
- Glenair's 234-205 connectors are designed to meet the applicable performance and interface requirements of MIL-DTL-38999,
- Connector is supplied with contacts (including spares), insertion/removal tool, and sealing plugs where indicated in Table II.
- Blue color band indicates rear release retention system.
- Insert arrangement is in accordance with MIL-STD-1560. Contact manufacturer for additional arrangement options.

MIL-DTL-38999 Series IV Type
234-205 Plug with wing-lock coupling

ENVIRONMENTAL CONNECTORS

TABLE IV -2 LOW-PROFILE WING-NUT DIMENSIONS

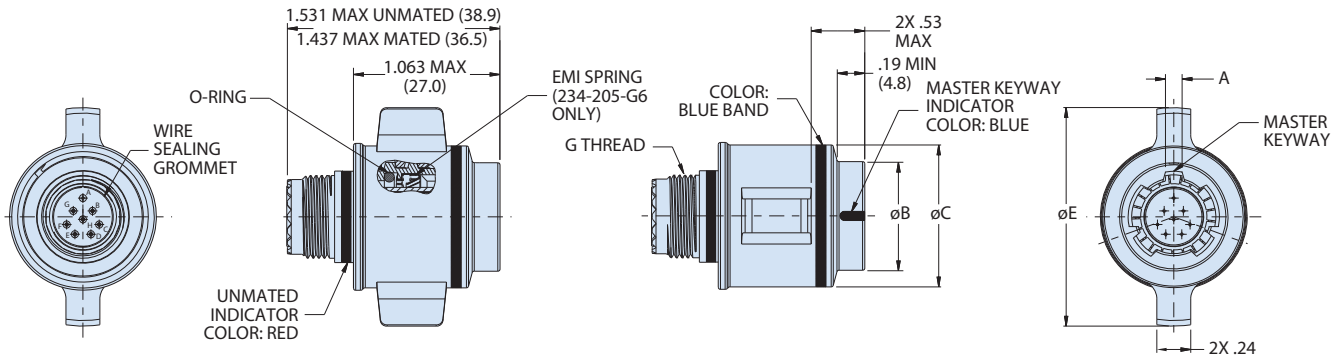

Shell Size	Shell Size Code	A		ØB Max	ØC Max	G Thread	ØE Max
		Socket	Pin				
11	B	.116 (2.95)	.076 (1.93)	.776 (19.7)	1.047 (26.6)	M15 X 1.0-6g 0.100R	1.55 (39.4)
13	C	.117 (2.97)	.077 (1.96)	.902 (22.9)	1.220 (31.0)	M18 X 1.0-6g 0.100R	1.71 (43.4)
15	D	.137 (3.48)	.097 (2.46)	1.039 (26.4)	1.346 (34.2)	M22 X 1.0-6g 0.100R	1.85 (47.0)
17	E			1.150 (29.2)	1.472 (37.4)	M25 X 1.0-6g 0.100R	1.96 (49.8)
19	F	.157 (3.99)	.117 (2.97)	1.276 (32.4)	1.583 (40.2)	M28 X 1.0-6g 0.100R	2.08 (52.8)
21	G			1.402 (35.6)	1.705 (43.3)	M31 X 1.0-6g 0.100R	2.21 (56.1)
23	H	.177 (4.50)	.137 (3.48)	1.528 (38.8)	1.831 (46.5)	M34 X 1.0-6g 0.100R	2.33 (59.2)
25	J			1.650 (41.9)	1.957 (49.7)	M37 X 1.0-6g 0.100R	2.46 (62.5)