



MIL-DTL-38999 Series IV Type
234-208 Panel mount receptacles with PC tails, stepped contacts

ENVIRONMENTAL CONNECTORS

"BETTER-THAN-QPL" FEATURES AND BENEFITS

- Secure breach-lock mating connector meets D38999 shock and vibrate
- Glenair Signature Tin Zinc finish class is RoHS compliant and cadmium compatible
- Precision-machined key/keyway polarization for reliable mismatching protection
- Scoop-proof design prevents pin damage and short circuits
- Fully tooled for all MIL-STD-1560 insert arrangements
- Contact options include size #22D, #20, #16, and #12 (see High-Speed series for Size #8)
- 500 mating cycles exceeds MIL-DTL-38999 specification

HOW TO ORDER							
Sample Part Number	234-208	-D0	NF	11	-35	P	N
Basic Part Number	234-208						
Connector Style	D0 - Receptacle, wall-mount through holes HM = Receptacle, wall-mount w/metric helicoil HS = Receptacle, wall-mount w/standard helicoil						
Material/Finish	(See Table I)						
Shell Size	11, 13, 15, 17, 19, 21, 23, 25						
Insert Arrangement	PER MIL-STD-1560						
Insert Designator	P = Pin Contacts, Gold Plate, 1500 Cycles S = Socket Contact Gold Plate, 1500 Cycles H = Pin Contacts Pd/Ni, 1500 Cycles J = Socket Contact Pd/Ni, 1500 Cycles						
Alternate Polarization	A, B, C, D, K, L, M, R, N = Normal, U = Universal (Glenair Equivalent Only)						

TABLE I - MATERIAL/FINISH			
Equiv Class	Sym	Material	Finish
W	NF	Aluminum Alloy	Cad/O.D. over Electroless Nickel
G*	MA**		Electroless Nickel, Matte
T*	MT		Nickel-PTFE
F	ME		Electroless Nickel
AA	MN		MegaNickel
V	TZ		Tin-Zinc
Z*	ZR		Zinc Ni, Black (Tri-Valent CR)
K*	Z1	Stainless Steel	Passivate
L*	ZL		Electrodeposited Nickel

* = Glenair Equivalent Only

** = Connectors for space applications must be ordered with "MA" finish and mod code "-186T" to conform to the thermal vacuum outgassing requirements of class G.

TABLE II - POLARIZING POSITIONS										
	N	A	B	C	D	K	L	M	R	U
X	110°	100°	90°	80°	70°	120°	120°	120°	120°	N/A
Y	250°	260°	270°	280°	290°	255°	265°	275°	285°	N/A

TABLE III		
Contact Size	PC Tail ØM	PC Tail ØN
#23	.020 (0.51)	
	.018 (0.46)	
#22	.020 (0.51)	.050 (1.27)
	.018 (0.46)	.044 (1.12)
#20	.030 (0.76)	.060 (1.52)
	.028 (0.71)	.054 (1.37)
#16	.040 (1.02)	.076 (1.93)
	.038 (0.97)	.070 (1.78)
#12	.072 (1.83)	.106 (2.69)
	.070 (1.78)	.100 (2.54)

MIL-DTL-38999 Series IV Type
234-208 Panel mount receptacles with PC tails, stepped contacts

ENVIRONMENTAL CONNECTORS

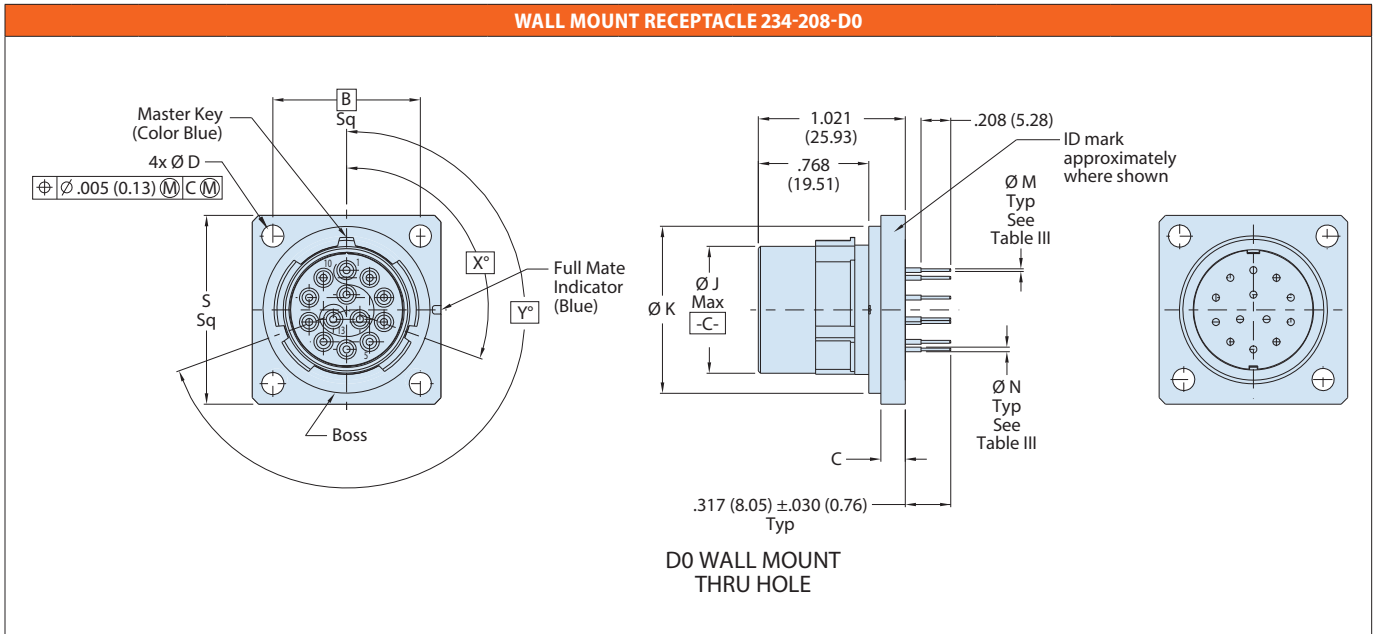

Shell Size	Shell Size Code	B Bsc	C	C'	Ø D	Ø J Max	Ø K	L Thread	L' Thread	S	S'
11	B	.812 (20.62)	.102 (2.6) .083 (2.1)	.179 (4.5) .140 (3.6)	.138 (3.5) .122 (3.1)	.509 (12.93)	.793 (20.15) .778 (19.76)	.112-40 UNC	M3 X 0.5	1.051 (26.7) 1.008 (25.6)	1.202 (30.5) 1.162 (29.5)
13	C	.906 (23.02)	.102 (2.6) .083 (2.1)		.138 (3.5) .122 (3.1)	.634 (16.10)	.913 (23.35) .904 (22.96)			1.146 (29.1) 1.102 (28.0)	1.296 (32.8) 1.256 (31.9)
15	D	.969 (24.61)	.102 (2.6) .083 (2.1)		.138 (3.5) .122 (3.1)	.759 (19.28)	1.044 (26.52) 1.029 (26.13)			1.240 (31.5) 1.197 (30.4)	1.359 (34.5) 1.319 (33.5)
17	E	1.062 (26.98)	.102 (2.6) .083 (2.1)		.138 (3.5) .122 (3.1)	.885 (22.48)	1.170 (29.72) 1.155 (29.33)			1.335 (33.9) 1.291 (32.8)	1.452 (36.9) 1.412 (35.9)
19	F	1.156 (29.36)	.102 (2.6) .083 (2.1)		.138 (3.5) .122 (3.1)	1.009 (25.63)	1.294 (32.87) 1.279 (32.48)			1.461 (37.1) 1.417 (36.0)	1.546 (39.3) 1.506 (38.3)
21	G	1.250 (31.76)	.134 (3.4) .114 (2.9)		.138 (3.5) .122 (3.1)	1.134 (28.80)	1.419 (36.05) 1.404 (35.66)			1.583 (40.2) 1.539 (39.1)	1.640 (41.7) 1.600 (40.6)
23	H	1.375 (34.93)	.134 (3.4) .114 (2.9)	.190 (4.8) .170 (4.3)	.157 (4.0) .142 (3.6)	1.259 (31.98)	1.544 (39.22) 1.529 (38.83)	.138-32 UNC	M4 X 0.7	1.709 (43.4) 1.665 (42.3)	1.765 (44.8) 1.725 (43.8)
25	J	1.500 (38.10)	.134 (3.4) .114 (2.9)		.157 (4.0) .142 (3.6)	1.384 (35.15)	1.669 (42.40) 1.654 (42.01)			1.835 (46.6) 1.791 (45.5)	1.890 (48.0) 1.850 (47.0)

TABLE IV - PANEL CUT-OUT

Shell Size	Shell Size Code	ØKK Min	BB Bsc	ØDD	ØLL Min
11	B	0.796 (20.22)	0.812 (20.62)	.133/.123	0.625 (15.88)
13	C	0.922 (23.42)	0.906 (23.01)		0.750 (19.05)
15	D	1.047 (26.59)	0.969 (24.61)		0.906 (23.01)
17	E	1.219 (30.96)	1.062 (26.97)		1.016 (25.81)
19	F	1.297 (32.94)	1.156 (29.36)		1.141 (28.98)
21	G	1.422 (36.12)	1.250 (31.75)		1.266 (32.16)
23	H	1.547 (39.29)	1.375 (34.93)	.159/.149	1.375 (34.93)
25	J	1.672 (42.47)	1.500 (38.10)	.155/.145	1.484 (37.69)

Labels in diagram: BB, ØKK, ØDD, 4X ØDD, -A-, $\oplus \ominus \varnothing .005 (0.13) \text{ (M) A (M)}$

MIL-DTL-38999 Series IV Type
234-208 Panel mount receptacles with PC tails, stepped contacts

ENVIRONMENTAL CONNECTORS

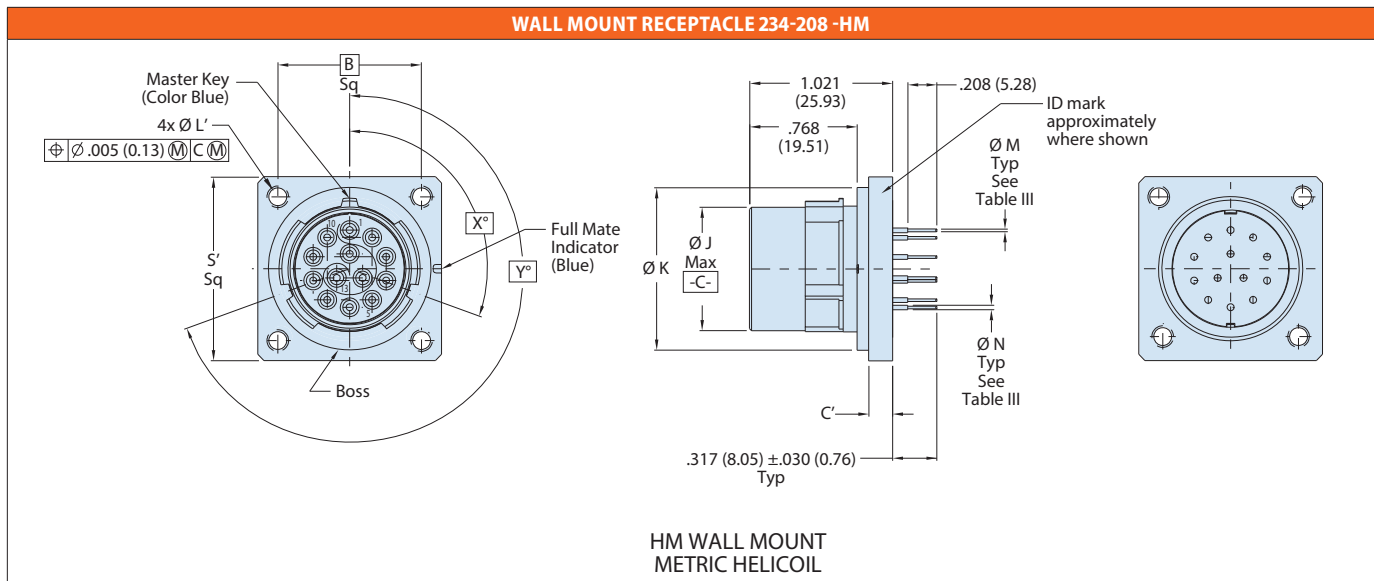
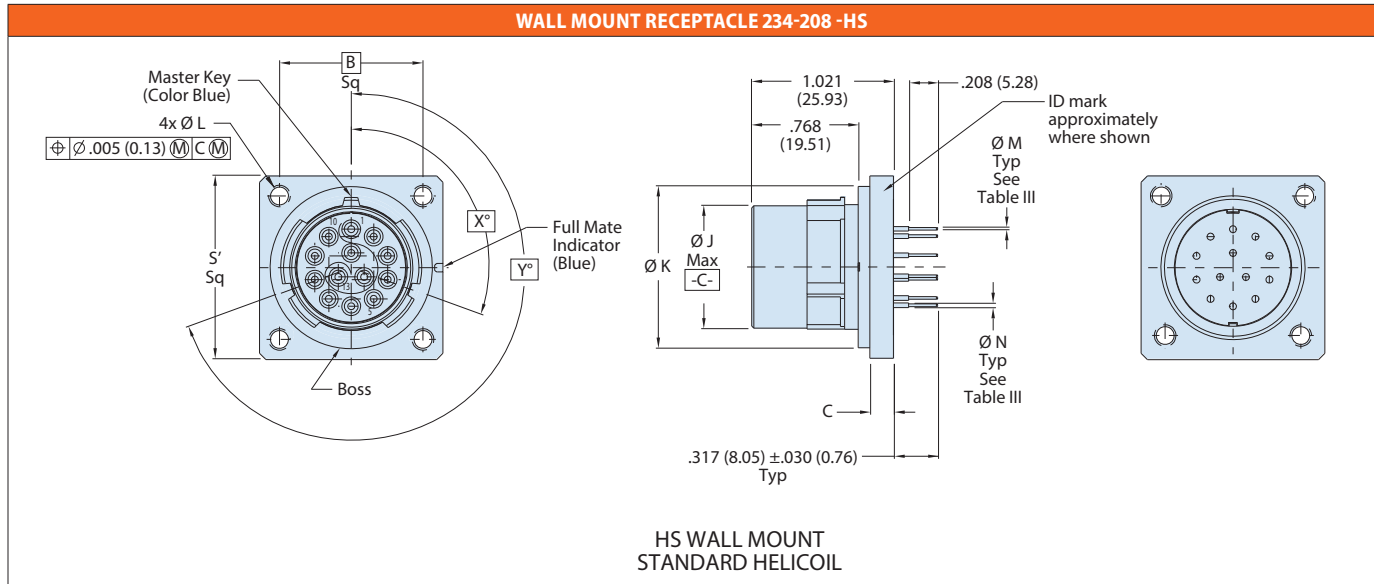

NOTES

1. Material/Finish:
 - Shell Finish - See Table I
 - Insulator - High Grade Rigid Dielectric
 - Contacts - Copper Alloy
 - Potting - Epoxy.
2. Insert arrangement in accordance with MIL-STD-1560. Contact factory for additional insert arrangements.
3. Insert arrangement shown is for reference only.
4. Glenair 234-208 series connectors are designed to meet the applicable performance and interface requirements of MIL-DTL-38999, Series IV except as noted. Connector mates with any QPL manufacturer's MIL-DTL-38999 Series IV connectors with the same size insert, arrangement, and polarization.
5. Glenair's 234-208 receptacle connector is designed to withstand a minimum of 1500 mating durability cycles when mate to a "Super Nine" plug and appropriate contacts finish should be the same for both mating connectors to optimize performance.