

MIL-DTL-38999 Series IV Type, QPL Qualified 38999/48 weld mount receptacle

HERMETIC CONNECTORS

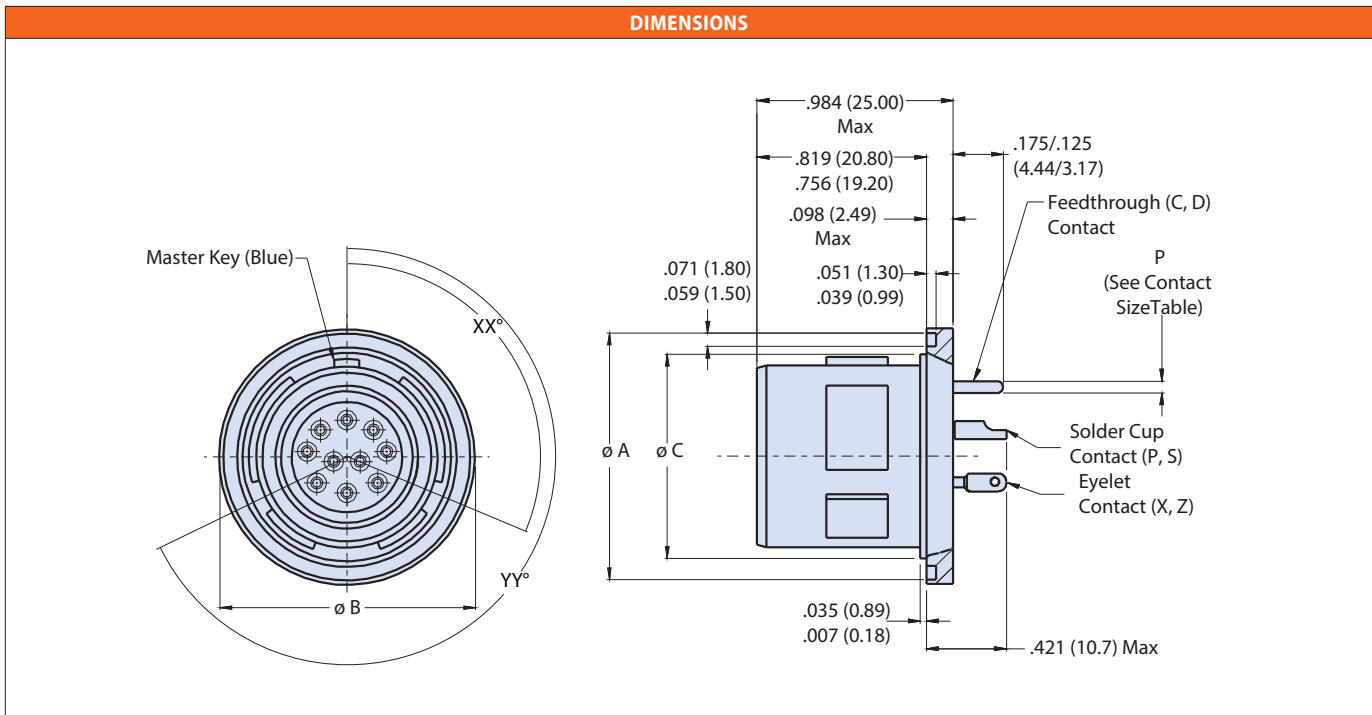

| HOW TO ORDER | |
|---------------------------|--|
| Sample Part Number | D38999/48 Y B 35 P N |
| D38999 | 38999/48 = Weld mount receptacle |
| Class | N = Hermetic, CRES, nickel finish, conductive, -65°C to 200°C Y = Hermetic, CRES, passivate finish, conductive, -65°C to 200°C H = Hermetic, CRES, passivate finish, conductive, -65°C to 200°C (space grade) |
| Shell Size | B, C, D, E, F, G, H, J |
| Insert Arrangement | Per MIL-STD-1560; See reference information section for details |
| Contact Style | P = Pin, solder cup X = Pin, eyelet C = Pin, PCB flex feedthrough S = Socket, solder cup Z = Socket, eyelet D = Socket, PCB flex feedthrough |
| Polarization | N (Normal), A, B, C, D, K, L, M, R ; see polarization positions table |



| Wire Accommodation | |
|--------------------|------------|
| Contact Size | Wire Gauge |
| 22D | #22 - #28 |
| 20 | #20 - #24 |
| 16 | #16 - #20 |
| 12 | #12 - #14 |

| Polarization | | | | | | | | | |
|--------------|------|------|------|------|------|------|------|------|------|
| | N | A | B | C | D | K | L | M | R |
| XX | 110° | 100° | 90° | 80° | 70° | 120° | 120° | 120° | 120° |
| YY | 250° | 260° | 270° | 280° | 290° | 255° | 265° | 275° | 285° |