

**MIL-DTL-38999 Series III Type**

**870H001 Swing-Arm Saddle Clamp**

BACKSHELLS AND ACCESSORIES

**Self-Locking**



*Self-locking, adjustable arms.* 870H001 Swing-Arm saddle clamp fits MIL-DTL-38999 Series III and IV connectors. Use with unshielded wire bundles. Adjustable arms pivot to 0°, 45° or 90° positions. Arms have self-locking threaded inserts to withstand high vibration. Full radius saddles have self-locking clinch nuts. Available in two clamp sizes: standard clamp fits most wire bundles, large clamp has increased clearance for oversize wire bundles. Coupling nut has anti-decoupling mechanism for audible detented coupling and prevents backoff under high vibration. Available in composite, aluminum or stainless steel.

**Adapter Code H**

This accessory fits these connectors:  
MIL-DTL-38999 Series III and Series IV

**ALUMINUM AND SST VERSIONS**

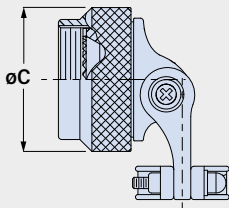

Aluminum and stainless steel versions have round knurled coupling nuts.

**PART NUMBER**

	<b>870H001</b>	<b>XB</b>	<b>23</b>	<b>B</b>						
<b>Base P/N</b>	<b>870H001</b>									
<b>Material/Finish</b>	<i>Composite</i>									
	<b>XB</b> No Finish (Black)									
	<i>Aluminum</i>									
	<b>M</b> Electroless Nickel									
	<b>NF</b> Olive Drab Cadmium									
	<b>MT</b> Nickel-PTFR									
<b>TZ</b> Tin-Zinc										
<b>ZR</b> Black Zinc-Nickel										
<i>Stainless Steel</i>										
<b>Z1</b> Passivated										
<b>Shell Size</b>	Shell Size	9	11	13	15	17	19	21	23	25
	Size Code	<b>09</b>	<b>11</b>	<b>13</b>	<b>15</b>	<b>17</b>	<b>19</b>	<b>21</b>	<b>23</b>	<b>25</b>
<b>Clamp Size</b>	<b>A</b>	Standard Clamp								
	<b>B</b>	Large Clamp								

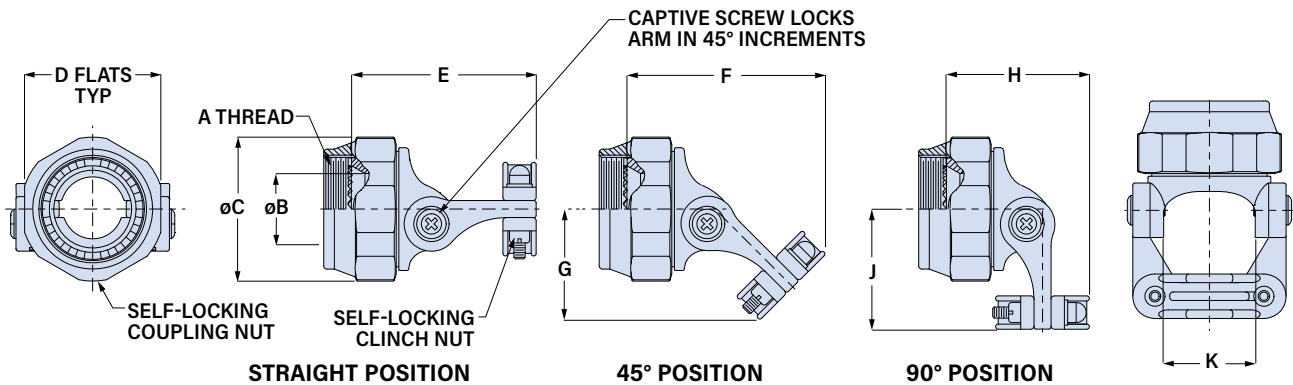

Shell Size	A Thread	øB Min	C Max	D Flats	E Max	F Max	G Max	H Max	J Max	K Ref.									
		in	mm	in	mm	in	mm	in	mm	in	mm								
9 (A)	M12X1.0-6H	.264	6.7	.812	20.6	.750	19.1	1.43	36.3	1.35	34.3	.78	19.8	.91	23.1	.87	22.1	.393	10.0
11 (B)	M15X1.0-6H	.390	9.9	.938	23.8	.875	22.2	1.50	38.1	1.45	36.8	.87	22.1	.94	23.9	.96	24.4	.455	11.6
13 (C)	M18X1.0-6H	.504	12.8	1.125	28.6	1.000	25.4	1.56	39.6	1.60	40.6	.97	24.6	1.12	28.4	1.03	26.2	.598	15.2
15 (D)	M22X1.0-6H	.630	16.0	1.250	31.8	1.125	28.6	1.57	39.9	1.68	42.7	1.02	25.9	1.21	30.7	1.10	27.9	.710	18.0
17 (E)	M25X1.0-6H	.756	19.2	1.375	34.9	1.250	31.8	1.66	42.2	1.78	45.2	1.09	27.7	1.29	32.8	1.16	29.5	.839	21.3
19 (F)	M28X1.0-6H	.843	21.4	1.500	38.1	1.375	34.9	1.66	42.2	1.86	47.2	1.14	29.0	1.39	35.3	1.22	31.0	.934	23.7
21 (G)	M31X1.0-6H	.969	24.6	1.625	41.3	1.500	38.1	1.81	46.0	2.02	51.3	1.24	31.5	1.50	38.1	1.29	32.8	1.068	27.1
23 (H)	M34X1.0-6H	1.091	27.7	1.750	44.5	1.625	41.3	1.84	46.7	2.09	53.1	1.30	33.0	1.57	39.9	1.36	34.5	1.197	30.4
25 (J)	M37X1.0-6H	1.217	30.9	1.875	47.6	1.750	44.5	2.00	50.8	2.20	55.9	1.45	36.8	1.64	41.7	1.55	39.4	1.323	33.6

**MIL-DTL-38999 Series III Type**

**870H001 Swing-Arm Saddle Clamp**

**CLAMP DIMENSIONS**

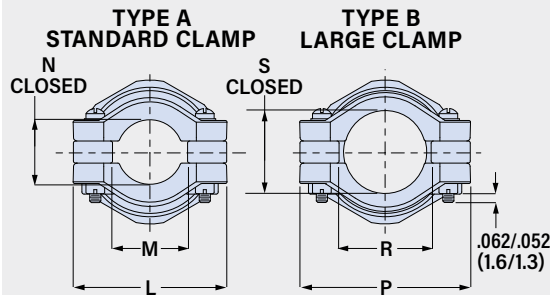

Shell Size	Standard Clamp				Large Clamp							
	L Max in	L Max mm	M Min in	M Min mm	N Ref. in	N Ref. mm	P Max in	P Max mm	R Min in	R Min mm	S Ref. in	S Ref. mm
9 (A)	.98	24.9	.22	5.6	.265	6.7	.98	24.9	.33	8.4	.356	9.0
11 (B)	1.05	26.7	.27	6.9	.310	7.9	1.20	30.5	.45	11.4	.422	10.7
13 (C)	1.20	30.5	.35	8.9	.422	10.7	1.45	36.8	.62	15.7	.637	16.2
15 (D)	1.30	33.0	.47	11.9	.538	13.7	1.54	39.1	.68	17.3	.707	18.0
17 (E)	1.44	36.6	.55	14.0	.590	15.0	1.60	40.6	.80	20.3	.759	19.3
19 (F)	1.56	39.6	.62	15.7	.660	16.8	1.73	43.9	.90	22.9	.841	21.4
21 (G)	1.69	42.9	.70	17.8	.744	18.9	1.95	49.5	1.05	26.7	.996	25.3
23 (H)	1.77	45.0	.78	19.8	.826	21.0	2.08	52.8	1.18	30.0	1.060	26.9
25 (J)	1.89	48.0	.85	21.6	.896	22.8	2.32	58.9	1.30	33.0	1.124	28.5

**MATERIAL/FINISH**

**Composite (Code XB)**

- Coupling nut, body, arms, saddles: polyetherimide (PEI), unplated
- Screws, washers, inserts: stainless steel/passivated
- Anti-decoupling springs: thermoplastic
- Clinch Nuts: stainless steel, silver plated

**Aluminum (Codes M, MT, NF, TZ, ZR)**

- Coupling nut, body, arms, saddles: aluminum
- Screws, washers, inserts: stainless steel/passivated
- Anti-decoupling springs: thermoplastic
- Clinch Nuts: Codes M, MT, TZ and ZR: stainless steel, silver plated.
- Code NF: stainless steel/ olive drab cadmium

**Stainless Steel (Code Z1)**

- Coupling nut, body, arms, saddles: SST
- Screws, washers, inserts: stainless steel/passivated
- Anti-decoupling springs: stainless steel
- Clinch Nuts: stainless steel, silver plated