

**MIL-DTL-38999 Series III Type**

**2333-2007 dual flange, jam-nut mount receptacle with PC tails**

ENVIRONMENTAL CONNECTORS

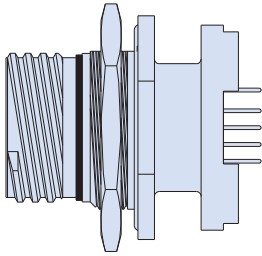

Part Number Development						
<b>Sample Part Number</b>	<b>2333-2007</b>	<b>NF</b>	<b>17-8</b>	<b>P</b>	<b>N</b>	<b>L</b>
<b>Series / Basic Part No.</b>	2333-2007 = SuperNine dual flange receptacle with epoxy sealed PC tails					
<b>Finish</b>	NF = Al alloy/cadmium olive drab ZR = Al alloy/black zinc nickel MT = Al alloy/nickel PTFE ME = Al alloy/electroless nickel Consult factory for additional finish options					
<b>Shell Size-Insert Arrangement*</b>	Per MIL-STD-1560					
<b>Contact Type</b>	P = Pin, P.C. termination    S = Socket, P.C. termination					
<b>Alternate Polarization*</b>	A, B, C, D, E, N = Normal (IAW MIL-DTL-38999 Series III)					
<b>PC Tail Length</b>	L = .280 (7.11) min    Omit for basic .142 (3.61)					

**NOTES**

- Glenair's 2333-2007 receptacle connector is designed with fixed PC tail contacts. Connector potting process meets or exceeds ingress protection rating IP67 and is environmentally sealed with a leak rate of  $< 1 \times 10^{-4}$  ccHe/sec in an unmated condition
- Insert arrangement is in accordance with MIL-STD-1560. Contact manufacturer for additional arrangement options. Insert arrangement shown is for reference only.
- Glenair P/N 2333-2007 receptacle is designed to meet or exceed the mechanical, dimensional, electrical, and environmental requirements of MIL-DTL-38999, D38999/24, and MIL-STD-1560 except as shown and/or noted. Receptacle mates with any QPL manufacturer's MIL-DTL-38999, Series III plug connector, D38999/26, having the same shell size, insert arrangement and polarization.
- Modified major diameter 31.95 - 31.80 (1.257 - 1.252).
- Material / finish:
  - Shell, jam-nut - see P/N development
  - Contacts - copper alloy / gold plate
  - Insulator - rigid dielectric
  - Seals - fluorosilicone blend
  - Potting - epoxy
  - O-ring - silver plated aluminum in fluorosilicone
  - (Cho-seal 1298 or equivalent)

**MIL-DTL-38999 Series III Type**

**2333-2007 dual flange, jam-nut mount receptacle with PC tails**

**07 - DUAL FLANGE JAM-NUT MOUNT RECEPTACLE**

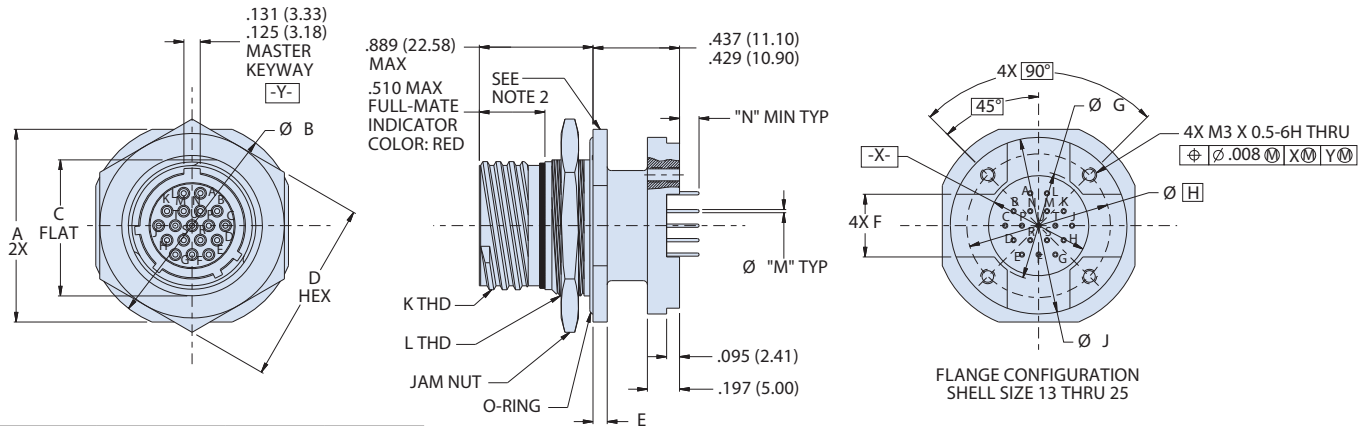

PC Tail Diameter			
Contact Size	PC Tail Ø "M"	"N" Min Length	
		Basic	"L"
22	.022 (0.56) .018 (.46)	.142 (3.61)	.280 (7.11)
20	.032 (0.81) .027 (0.69)	.142 (3.61)	.280 (7.11)
16	.042 (1.07) .038 (0.97)	.142 (3.61)	.280 (7.11)
12	.096 (2.44) .092 (2.34)	.142 (3.61)	.280 (7.11)

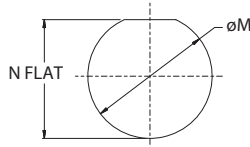

**Recommended Panel Cut-out**

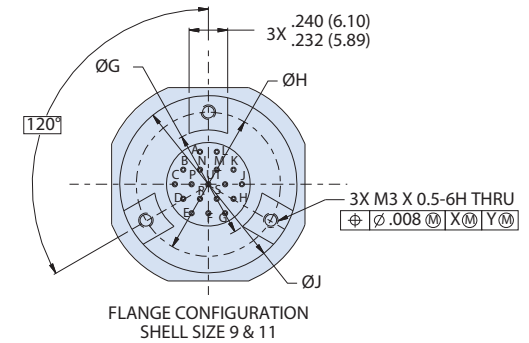

Dimensions														
SHELL SIZE CODE	SHELL SIZE REF	A ±.016	Ø B ±.012	C FLAT ±.005	D HEX ±.015	E ±.016	F ±.004	Ø G ±.006	Ø H BSC	Ø J ±.006	K THREAD CLASS 2A .1P-.3L-TS (PLATED)	L THREAD METRIC (PLATED)	Ø M	N FLAT
A	9	1.063 (27.00)	1.189 (30.20)	0.650 (16.51)	0.945 (24.00) 0.859 (21.82)	0.098 (2.49)		0.594 (15.09)	0.807 (20.50)	1.024 (26.01)	0.625 (15.88)	M17 x 1-6g-0.10R	0.703 (17.86) 0.693 (17.60)	0.661 (16.79) 0.654 (16.61)
B	11	1.252 (31.80)	1.374 (34.90)	0.750 (19.05)	1.063 (27.00) 0.984 (24.99)	0.098 (2.49)		0.783 (19.89)	0.992 (25.20)	1.213 (30.81)	0.7500 (19.05)	M20 x 1-6g-0.10R	0.835 (21.21) 0.825 (20.96)	0.771 (19.58) 0.761 (19.33)
C	13	1.374 (34.90)	1.500 (38.10)	0.937 (23.80)	1.260 (32.00) 1.172 (29.77)	0.098 (2.49)	0.476 (12.09)	0.783 (19.89)	0.994 (25.25)	1.213 (30.81)	0.8750 (22.23)	M25 x 1-6g-0.10R	1.020 (25.91) 1.010 (25.65)	0.955 (24.26) 0.945 (24.00)
D	15	1.500 (38.10)	1.626 (41.30)	1.061 (26.95)	1.417 (35.99) 1.296 (32.92)	0.098 (2.49)	0.555 (14.10)	0.906 (23.01)	1.119 (28.42)	1.335 (33.91)	1.0000 (25.40)	M28 x 1-6g-0.10R	1.145 (29.08) 1.135 (28.83)	1.085 (27.56) 1.075 (27.31)
E	17	1.626 (41.30)	1.752 (44.50)	1.186 (30.12)	1.457 (37.01) 1.422 (36.12)	0.098 (2.49)	0.634 (16.10)	1.024 (26.01)	1.237 (31.42)	1.449 (36.80)	1.1875 (30.16)	M32 x 1-6g-0.10R*	1.270 (32.26) 1.260 (32.00)	1.210 (30.73) 1.200 (30.48)
F	19	1.811 (46.00)	1.937 (49.20)	1.311 (33.30)	1.614 (41.00) 1.545 (39.24)	0.130 (3.30)	0.713 (18.11)	1.161 (29.49)	1.379 (35.03)	1.591 (40.41)	1.2500 (31.75)	M35 x 1-6g-0.10R	1.395 (35.43) 1.385 (35.18)	1.335 (33.91) 1.325 (33.66)
G	21	1.937 (49.20)	2.063 (52.40)	1.436 (36.47)	1.811 (46.00) 1.672 (42.47)	0.130 (3.30)	0.791 (20.09)	1.268 (32.21)	1.489 (37.82)	1.701 (43.21)	1.3750 (34.93)	M38 x 1-6g-0.10R	1.520 (38.61) 1.510 (38.35)	1.460 (37.08) 1.450 (36.83)
H	23	2.063 (52.40)	2.189 (55.60)	1.561 (39.65)	1.969 (50.01) 1.796 (45.62)	0.130 (3.30)	0.909 (23.09)	1.398 (35.51)	1.619 (41.12)	1.831 (46.51)	1.5000 (38.10)	M41 x 1-6g-0.10R	1.645 (41.78) 1.635 (41.53)	1.585 (40.26) 1.575 (40.01)
J	25	2.189 (55.60)	2.311 (58.70)	1.686 (42.82)	2.017 (51.23) 1.939 (49.25)	0.130 (3.30)	0.988 (25.10)	1.520 (38.61)	1.744 (44.30)	1.953 (49.61)	1.6250 (41.28)	M44 x 1-6g-0.10R	1.770 (44.96) 1.760 (44.70)	1.710 (43.43) 1.700 (43.18)

\*See note 4