



Part number development						
Sample Part Number	180-091	XW	T7	-17-8	P	N
Series / Basic Part No.	D38999 Series III Type					
Material/Finish	See Material/Finish Table					
Connector Style	T7 = Wall Mount Receptacle with Threaded Insert Holes					
Shell Size/Insert Arr.*	IAW MIL-DTL-38999 Series III, Per MIL-STD-1560					
Insert Designation	P = Pin S = Socket					
Alternate Key Position*	A, B, C, D, E, N = Normal; Per MIL-DTL-38999					

*See 'reference information' portion of this section for complete details

NOTES

1. Insert arrangement in accordance with MIL-STD-1560, see page G-12
2. Blue color band indicates rear release retention system. Yellow color band indicates fiber optic connector. Blue and yellow color bands are located approximately as shown - sequencing optional.
3. For recommended panel cutout, see page G-13
4. Material/Finish:
 - Shell: See Material and Finish Table
 - Insulator: High Grade Rigid Dielectric
 - Seals: Fluorosilicone

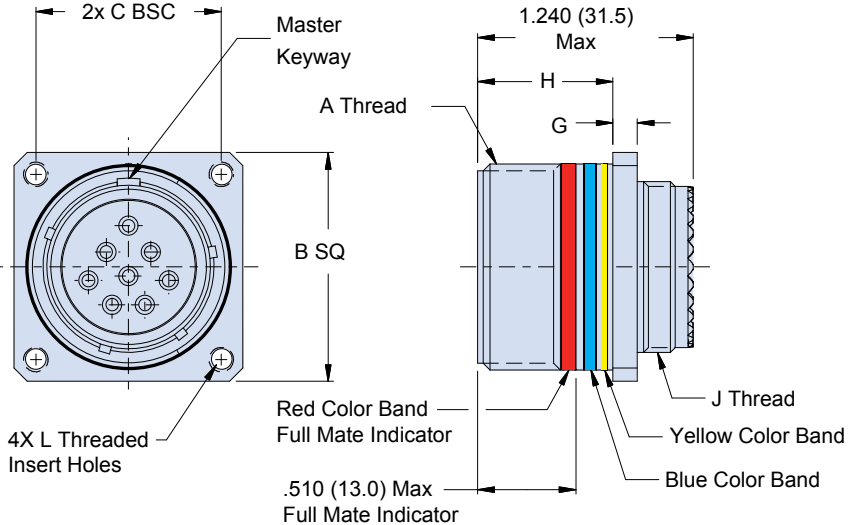

FIBER OPTIC CONNECTORS

Material and Finish		
Code	Material	Finish Description
M	Aluminum Alloy	Electroless Nickel
MT		Nickel - PTFE, Grey
ZNU		Zinc-Nickel, Black
ZR		Zinc-Nickel, Black (RoHS)
XM	Composite	Electroless Nickel
XMT		Nickel - PTFE, Grey
XW		Cadmium, Olive Drab
XZN		Zinc-Nickel, Black
MS	Stainless Steel	Electroless Nickel
ZL		Electro-Deposited Nickel
ZI		Passivate
AB	Marine Bronze	None (Clean Only)

Dimensions									
Shell Size Code	Shell Size Ref	A Thread .1P-.3L-TS-2A	B SQ	C BSC	G	H	J Thread 1.0-6g 0.100R	L Threaded Insert Holes	
B	11	.7500	1.043 (26.5) 1.019 (25.9)	.812 (20.6)	.144 (3.7) .083 (2.1)	.823 (20.9) .768 (19.5)	M15	.112-40 UNC-2B	
C	13	.8750	1.138 (28.9) 1.114 (28.3)	.906 (23.0)	.144 (3.7) .083 (2.1)	.823 (20.9) .768 (19.5)	M18	.112-40 UNC-2B	
D	15	1.0000	1.232 (31.3) 1.208 (30.7)	.969 (24.6)	.144 (3.7) .083 (2.1)	.823 (20.9) .768 (19.5)	M22	.112-40 UNC-2B	
E	17	1.1875	1.323 (33.6) 1.299 (33.0)	1.062 (27.0)	.144 (3.7) .083 (2.1)	.823 (20.9) .768 (19.5)	M25	.112-40 UNC-2B	
F	19	1.2500	1.449 (36.8) 1.425 (36.2)	1.156 (29.4)	.144 (3.7) .083 (2.1)	.823 (20.9) .768 (19.5)	M28	.112-40 UNC-2B	
G	21	1.3750	1.575 (40.0) 1.551 (39.4)	1.250 (31.8)	.171 (65.2) .083 (39.8)	.791 (20.0) .736 (18.7)	M31	.112-40 UNC-2B	
H	23	1.5000	1.701 (43.2) 1.677 (42.6)	1.375 (34.9)	.171 (65.2) .083 (39.8)	.791 (20.0) .736 (18.7)	M34	.138-32 UNC-2B	
J	25	1.6250	1.823 (46.3) 1.799 (45.7)	1.500 (38.1)	.171 (65.2) .083 (39.8)	.791 (20.0) .736 (18.7)	M37 x 1.0-6g 0.100R	.138-32 UNC-2B	