

MIL-DTL-38999 Series III Type

2333-2002 bulkhead feed-thru connector with BMB contacts

CODE RED HERMETIC CONNECTORS

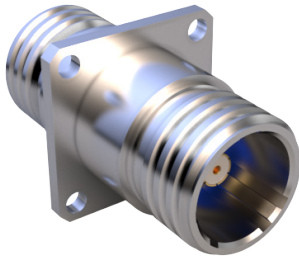

NOTES

- Material/finish:
Shell, jam-nut, bushing - per table I
seals, o-ring - fluorosilicone blend
sealing compound - polymer
encapsulant
Contact:
Outer/inner conductors - copper alloy
/ gold plate
insulators - PTFE
insulator (hermetic) - full glass
ferrule/pin (hermetic) - nickel-iron
alloy / gold plate
- Hermeticity = $< 1 \times 10^{-7}$ sccHe/sec @
1 atm delta
- For pin-pin feedthru, signal applied to
one contact will result in signal to the
contact directly opposite, regardless
of contact identification
- This receptacle connector mates with
special Glenair plug connector with
same polarization, size, arrangement,
(233-290) and with BMB socket
contact (852-256)
- BMB contact electrical performance:
impedance: 50 ohms nom
Frequency range: DC-18 ghz
VSWR: 1.5:1 Max
DWV: 1000 vac, inner pin to outer pin
IR: 5000 megaohms, inner pin to outer
pin
- Contact is non-removable and
common ground to connector body.
- Insert arrangement shown for
reference only.
- Assembly to be identified with
glenair's name, part number, and date
code, space permitting.
- Flycuts (wrench flats) are an optional
design.

Part Number Development					
Sample Part Number	2333-2002	-07	ME	11RFF1	N
Series / Basic Part No.	Series 23 SuperNine jam-nut CODE RED hermetic receptacle				
Connector Style	-07 = Jam-nut mount -D0 = Wall mount with round holes				
Material/Finish	See Material and Finish Table				
Insert Arrangement	See Insert Arrangement Table				
Polarization	A, B, C, D, E, N = Normal				

Material and Finish Table			
Code	Material	Finish	Temperature Range
NF	Aluminum Alloy	Cad/O.D. Over Electroless Nickel	-65°C TO +175°C
ZR	Aluminum Alloy	Zinc Ni, Black	-65°C TO +175°C
ME	Aluminum Alloy	Electroless Nickel	-65°C TO +200°C
Z1	Stainless Steel	Passivate	-65°C TO +200°C
ZL	Stainless Steel	Electro-Deposited Nickel	-65°C TO +200°C

Dimensions						
SHELL SIZE	A THREAD	ØB	C	ØD	E	F THREAD
11	.750-1P-.3L-TS-2A	1.375 (34.92)	1.252 (31.80)	.835 (21.21) .825 (20.96)	.771 (19.58) .761 (19.33)	M20 X 1-6g-.100R
17	1.1875-1P-.3L-TS-2A	1.752 (44.50)	1.626 (41.30)	1.270 (32.26) 1.260 (32.00)	1.210 (30.73) 1.200 (30.48)	M32 X 1-6g-.100R
19	1.250-1P-.3L-TS-2A	1.937 (49.20)	1.811 (46.00)	1.395 (35.43) 1.385 (35.18)	1.335 (33.91) 1.325 (33.65)	M35 X 1-6g-.100R
21	1.375-1P-.3L-TS-2A	2.063 (52.40)	1.937 (49.20)	1.520 (38.61) 1.510 (38.35)	1.460 (37.08) 1.450 (36.83)	M38 X 1-6g-.100R
23	1.500-1P-.3L-TS-2A	2.189 (55.60)	2.063 (52.40)	1.645 (41.78) 1.635 (41.53)	1.585 (40.26) 1.575 (40.00)	M41 X 1-6g-.100R
25	1.625-1P-.3L-TS-2A	2.311 (58.70)	2.189 (55.60)	1.770 (44.96) 1.760 (44.70)	1.710 (43.43) 1.700 (43.18)	M44 X 1-6g-.100R

Dimensions (cont.)					
SHELL SIZE	G SQ	H BSC	J	ØK	ØL
11	1.043 (26.49) 1.019 (25.88)	0.812 (20.62)	.820 (20.83) .771 (19.58)	0.796 (20.22)	.133 (3.38) .123 (3.12)
17	1.323 (33.60) 1.299 (32.99)	1.062 (26.97)	.820 (20.83) .771 (19.58)	1.219 (30.96)	.133 (3.38) .123 (3.12)
19	1.449 (36.80) 1.425 (36.20)	1.156 (29.36)	.820 (20.83) .771 (19.58)	1.297 (32.94)	.133 (3.38) .123 (3.12)
21	1.575 (40.00) 1.551 (39.40)	1.250 (31.75)	.790 (20.07) .741 (18.82)	1.422 (36.12)	.133 (3.38) .123 (3.12)
23	1.701 (43.21) 1.677 (42.60)	1.375 (34.92)	.790 (20.07) .741 (18.82)	1.547 (39.29)	.159 (4.04) .149 (3.78)
25	1.823 (46.30) 1.799 (45.69)	1.500 (38.10)	.790 (20.07) .741 (18.82)	1.672 (42.47)	.155 (3.94) .145 (3.68)

MIL-DTL-38999 Series III Type

2333-2002 Jam-nut mount, bulkhead feed-thru with BMB contacts

CODE RED HERMETIC CONNECTORS

2333-2002-07 AND D0 BULKHEAD FEED-THRU WITH PIN-PIN SIZE 8 BMB CONTACTS

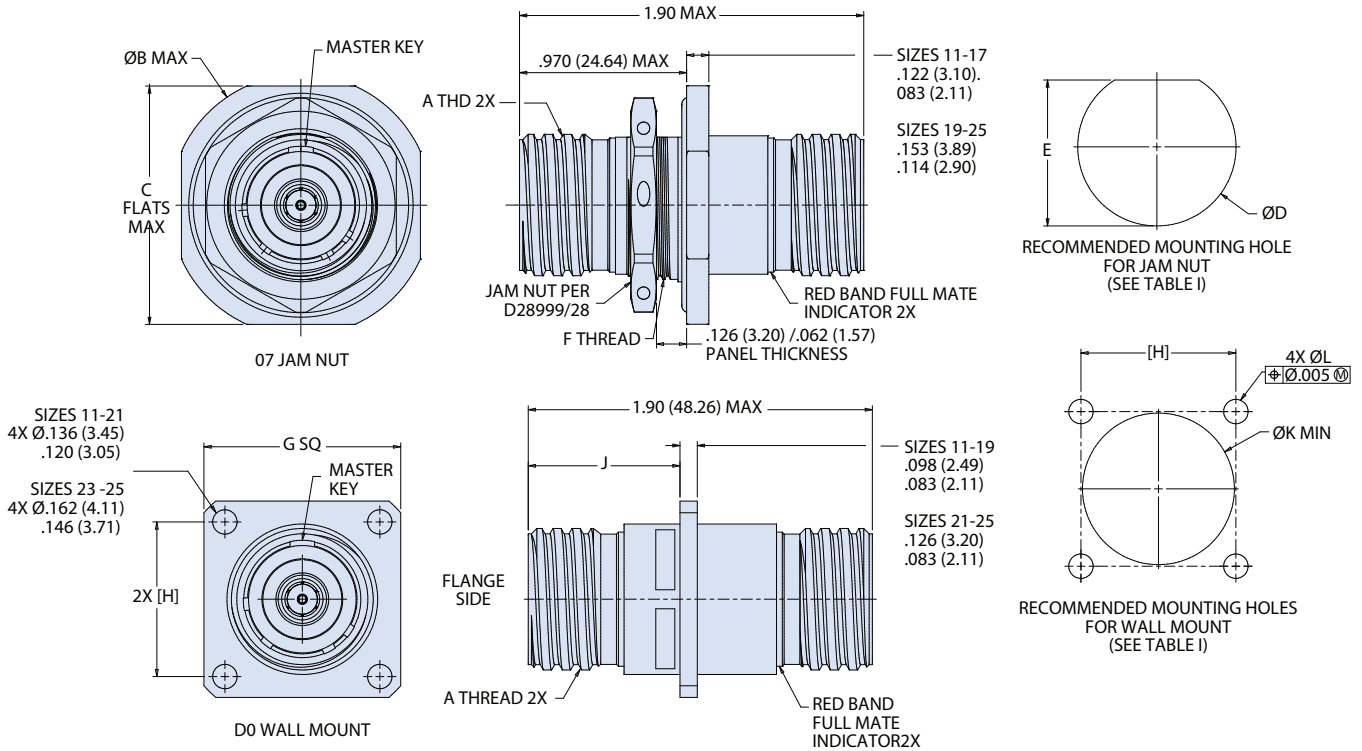

SIZE 8 BMB CONTACT INSERT ARRANGEMENTS

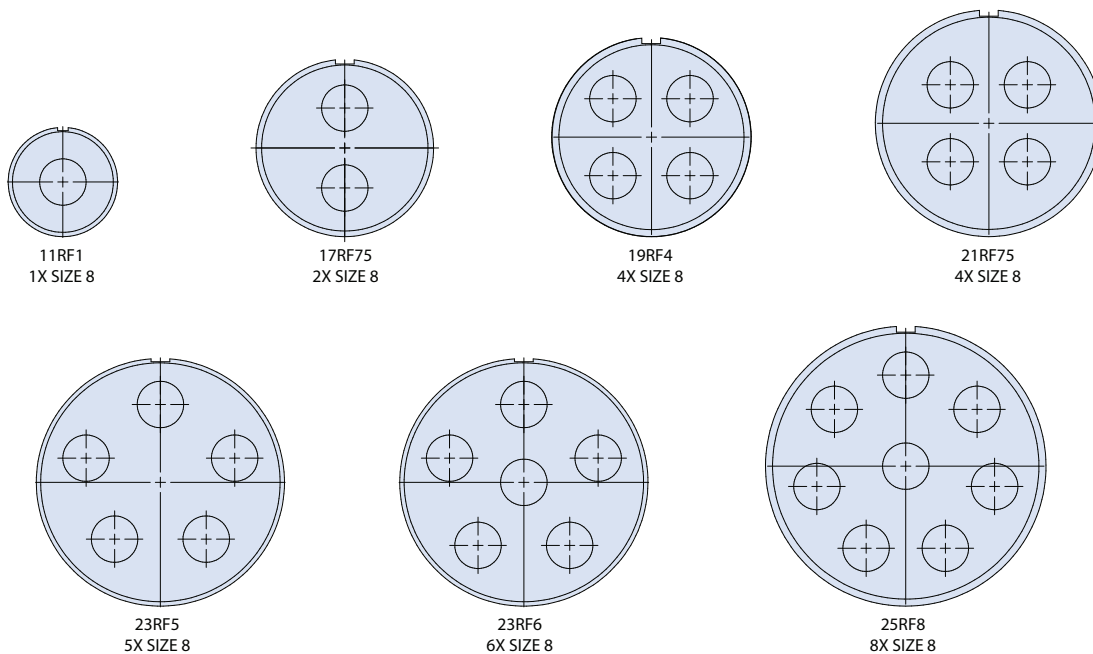

Insert Arrangement Layouts	
Layout	Contacts
11RF1	1 size 8
17RF75	2 size 8
19RF4	4 size 8
21RF75	4 size 8
23RF5	5 size 8
23RF6	6 size 8
25RF8	8 size 8