

MIL-DTL-38999 Series III Type Environmental Connectors

377HS121 Environmental Extender Backshell for #8 El Ochito Cables

HIGH-SPEED CONNECTORS

Part Number Development							
Sample Part Number	377	H	S	121	NF	17-75	4
Series	377 = Series 37 Aluminum Alloy Backshells						
Connector Designator*	H = MIL-DTL-38999 Series III & IV						
Angular Function	S = Straight						
Basic No.	121						
Material/Finish	See Finish Table						
Shell Size-Insert Arrangement	11, 19, 21, 25						
Length	In 1/2 Inch Increments; e.g. 4 = 2 inches; omit for standard 1.50 inches						

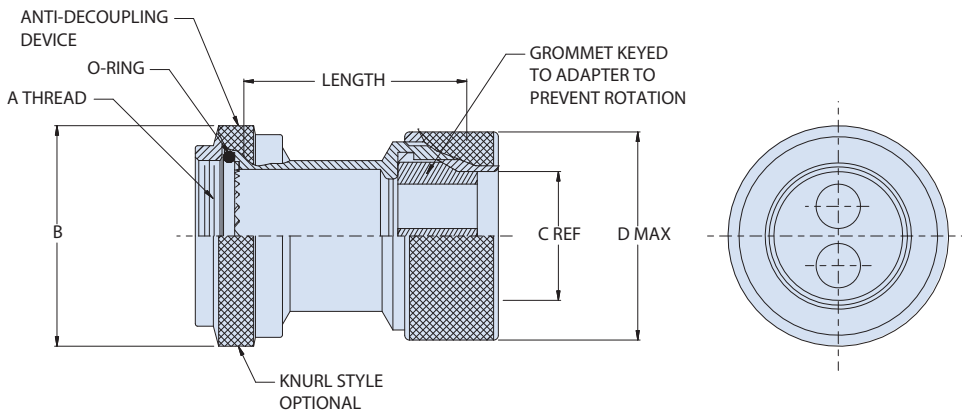

NOTES

- Glenair 600 series backshell assembly tools are recommended for assembly and installation
- Material:
 - Adapter, ferrule, coupling nut: see finish table
 - Grommet, O-ring: fluorosilicone/N.A.
 - Anti-rotation device: corrosion resistant material/N.A.

Dimensions				
SHELL SIZE	A THREAD ISO METRIC	B DIA	C REF	D MAX
09	M12 X 1.0 - 6H	0.89 (22.61)	0.562 (14.27)	1.03 (26.16)
11	M15 X 1.0 - 6H	1.01 (25.65)	0.562 (14.27)	1.03 (26.16)
17	M25 X 1.0 - 6H	1.42 (36.07)	0.812 (20.62)	1.34 (34.04)
19	M28 X 1.0 - 6H	1.50 (38.10)	0.812 (20.62)	1.34 (34.04)
21	M31 X 1.0 - 6H	1.67 (42.42)	1.062 (26.97)	1.90 (48.26)
23	M34 X 1.0 - 6H	1.78 (45.21)	1.062 (26.97)	1.90 (48.26)
25	M37 X 1.0 - 6H	1.91 (48.51)	1.312 (33.32)	2.20 (55.88)

Finish Table	
Sym	Finish Description
M	Electroless nickel
MT	Nickel - PTFE
NF	Aluminum alloy Cad/O.D. over electroless nickel (100 hour salt spray)
ZR	Zinc-nickel, black (1000 hour salt spray)

INSERT ARRANGEMENTS

