

## MIL-DTL-38999 Series III Type Environmental Connectors

### 8572-0001 Pre-wired El Ochito® USB 3.0 contacts, single-ended

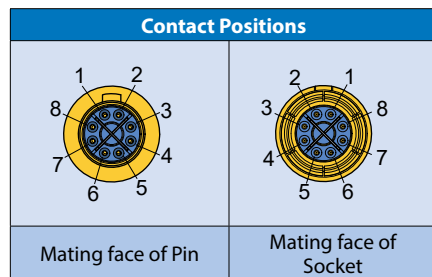

Ochito "Blue" for SuperSpeed USB  
Pin contact mating face



Technical Data	
<ul style="list-style-type: none"> <li>Refer to individual contact and cable data sheets for construction details</li> <li>100% tested for shorts, continuity and IR</li> </ul>	
<ul style="list-style-type: none"> <li><b>Operating temperature</b> Aero: -65° to +125°C Commercial: 0 to 80°C</li> </ul>	
<ul style="list-style-type: none"> <li><b>Impedance:</b> 90 ohms</li> <li><b>DWV:</b> 500 Vrms</li> <li><b>Current Rating:</b> 1.5 A</li> <li><b>IR:</b> 200 megohms min.</li> <li><b>Durability:</b> 500 mating cycles</li> </ul>	

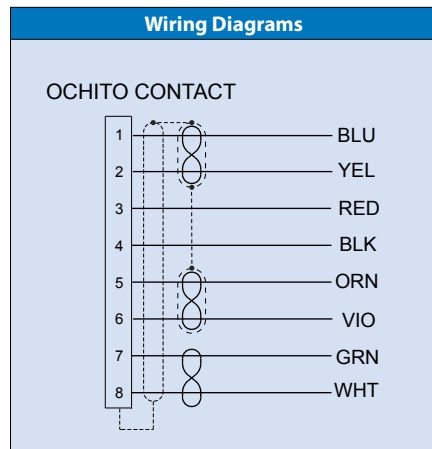

*Two cable options: commercial grade or flight-grade. 100% tested. Save assembly time and cost with pre-wired El Ochito® "Blue" SuperSpeed USB assemblies. These single-ended assemblies have Ochito "Blue" contacts terminated to USB 3 shielded cables. Supplied with cable sealing boot. Commercial-grade version has PVC jacket. Aerospace-grade version has high temperature fluoropolymer construction and braided shields on SuperSpeed pairs. Compatible with Glenair Series 23 connectors. **Ochito contacts should be installed in keyed connectors before mating to prevent misalignment and contact damage.***

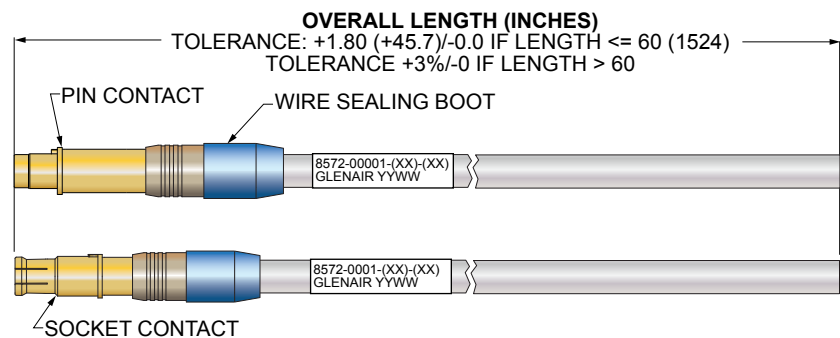

Part Number Development			
Sample Part Number	8572-0001	-01	-36
Series / Basic Part No.	8572-0001 = Pre-wired El Ochito® contact, with USB 3.0 cable		
Order Code	See Table I		
Length	Length in inches (12 inch minimum)		

Table I: Order Code						
Connector Type	Order Code	Pin Contact Part No.	Order Code	Skt. Contact Part No.	Cable Type	Cable Part Number
Series 23	01	858-028-01F	03	858-029-01F	Commercial-grade PVC Jacket 0° to +80°C	963-118
	02	858-028-02F	04	858-029-02F	Aerospace-grade Fluoropolymer Jacket -65° to +125°C	963-110

HIGH-SPEED CONNECTORS