

# HIGH TEMPERATURE ThermaRex HT Series 806 Accessories



## Swing-Arm Saddle Clamp, EMI Banding Adapter 870V005

THERMAREX™ HT



Shielded, self-locking, adjustable arms. 870V005 aluminum or stainless steel Swing-Arm saddle clamp fits Glenair Series 806 Mil-Aero connectors. Adjustable arms pivot to 0°, 45° or 90° positions. Banding adapter has optional "T" slots for pigtailed individual shields. Terminate shield braid to adapter with optional Band-Master ATS® pre-coiled banding strap. Full radius saddles with self-locking clinch nuts. Available in two clamp sizes: standard clamp fits most wire bundles, large clamp has increased clearance for oversize wire bundles. Coupling nut has anti-decoupling mechanism for audible detented coupling and prevents backoff under high vibration. Tested for 1000 hours at 300°C and in random vibration at 300°C.

### MATERIAL/FINISH

#### Stainless Steel (Code Z1)

- Coupling nut, body, arms, saddles, anti-decoupling springs, screws, washers, inserts: stainless steel, passivated
- Clinch nuts: stainless steel, silver plated
- Banding adapter: Code Z1: stainless steel/ passivated
- Band (optional): stainless steel/ passivated

### Banding Adapter Slots

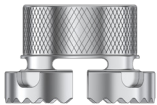

Route pigtail shield braids into optional "T" slots in banding adapter.

How To Order						
Sample Part Number	870V005	Z1	08	A	S	K
Series / Basic Part No.	870V005 Swing-Arm Saddle Clamp, EMI Banding Adapter					
Material/Finish	Z1 = SST Interface Ring, Passivated					
Shell Sizes	08, 09, 10, 11, 12, 14, 16, 18, 20, 22, 24					
Clamp Size	A = Standard Clamp B = Wide Mouth					
Banding Adapter Slots	Omit if not required. See Banding Adapter. S = "T" Slots in Banding Adapter for Shield Pigtails					
Band	Omit if not required. K = Pre-Coiled Micro Band included With Clamp J = Pre-Coiled Micro Slim Band included With Clamp					

### Dimensions

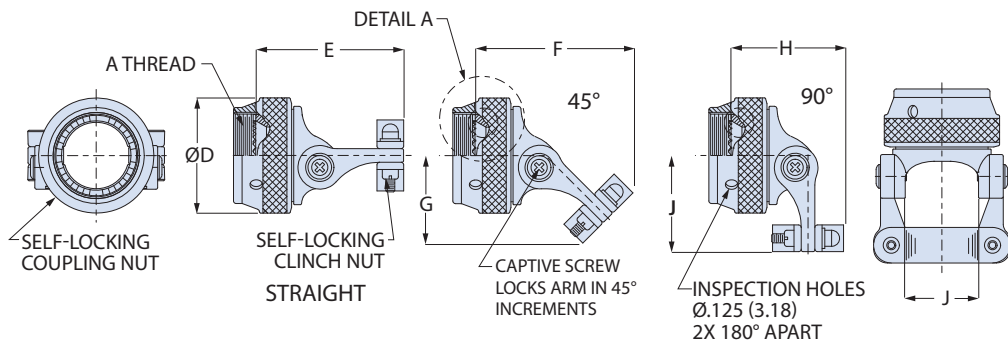

Shell Size	A Thread ISO Metric	øC Max	D Max	E Max	F Max	G Max	H Max	J Ref.
08	M10 x 1.0-6H	.812 (20.62)	1.55 (39.37)	1.45 (36.83)	.77 (19.56)	.98 (24.89)	.87 (22.10)	.393 (9.98)
09	M12 x 1.0-6H	.812 (20.62)	1.55 (39.37)	1.45 (36.83)	.77 (19.56)	.98 (24.89)	.87 (22.10)	.393 (9.98)
10	M14 x 1.0-6H	.938 (23.83)	1.61 (40.89)	1.56 (39.62)	.87 (22.10)	1.05 (26.67)	.96 (24.38)	.455 (11.56)
11	M15 x 1.0-6H	.938 (23.83)	1.61 (40.89)	1.56 (39.62)	.87 (22.10)	1.05 (26.67)	.96 (24.38)	.455 (11.56)
12	M17 x 1.0-6H	1.125 (28.58)	1.66 (42.16)	1.71 (43.43)	.97 (24.64)	1.22 (30.99)	1.03 (26.16)	.598 (15.19)
14	M19 x 1.0-6H	1.250 (31.75)	1.67 (42.42)	1.79 (45.47)	1.02 (25.91)	1.32 (33.53)	1.10 (27.94)	.710 (18.03)
16	M22 x 1.0-6H	1.250 (31.75)	1.67 (42.42)	1.79 (45.47)	1.02 (25.91)	1.32 (33.53)	1.10 (27.94)	.710 (18.03)
18	M25 x 1.0-6H	1.375 (34.92)	1.77 (44.96)	1.88 (47.75)	1.08 (27.43)	1.38 (35.05)	1.16 (29.46)	.839 (21.31)
20	M28 x 1.0-6H	1.500 (38.10)	1.77 (44.96)	1.96 (49.78)	1.13 (28.70)	1.49 (37.85)	1.22 (30.99)	.934 (23.72)
22	M31 x 1.0-6H	1.625 (41.28)	1.92 (48.77)	2.13 (54.10)	1.24 (31.50)	1.61 (40.89)	1.29 (32.77)	1.068 (27.13)
24	M34 x 1.0-6H	1.750 (44.45)	1.95 (49.53)	2.20 (55.88)	1.30 (33.02)	1.68 (42.67)	1.36 (34.54)	1.197 (30.40)

## Swing-Arm Saddle Clamp, EMI Banding Adapter 870V005

THERMAREX™ HT

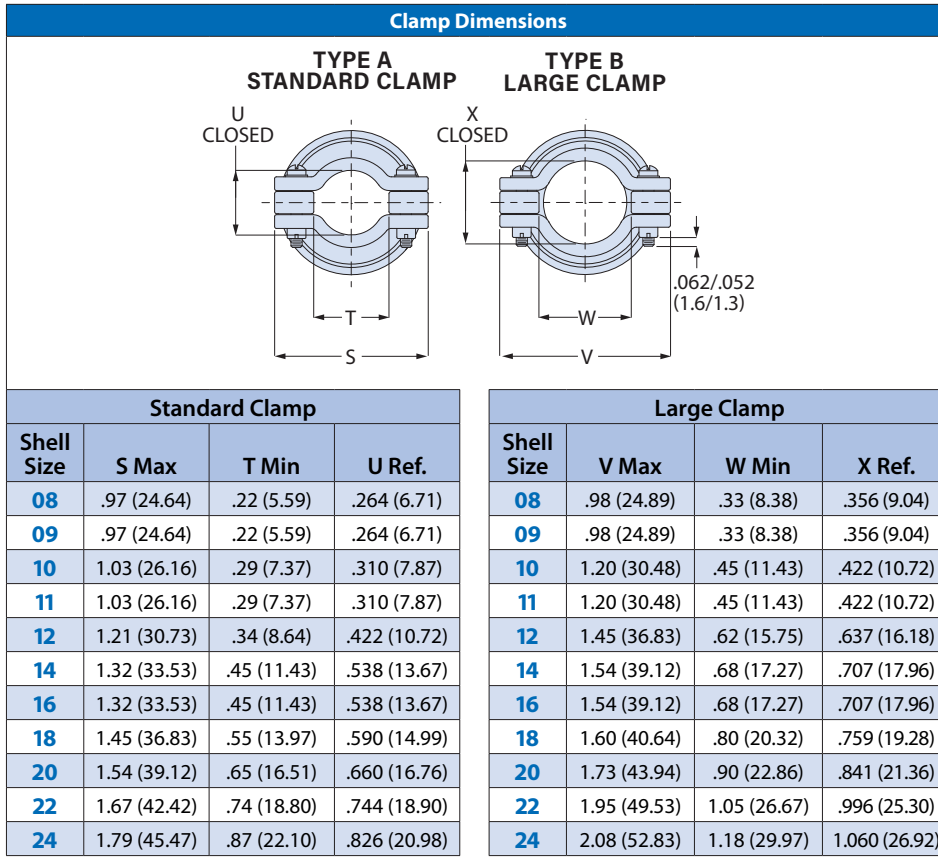

**Band information**

Terminate cable braid to band adapter with optional pre-coiled banding strap. Glenair's Band-Master ATS® banding system provides quick, easy, cost-effective and highly reliable termination. Band is passivated stainless steel.



Shell Size	Pre-Coiled Micro Band Part No.	Pre-Coiled Micro Slim Band Part No.	Length	Max Diameter
9 – 13	601-061	601-601	8.125 (206.38)	.88 (22.35)
15 – 25	601-065	601-603	14.25 (361.95)	1.88 (47.75)