

"ZERO-CROSSTALK" M83513 Micro-D VersaLink™ Connectors



GVLM-BS, Straight PCB Connector

MICRO-D VERSALINK CONNECTORS

MATERIALS AND FINISHES

- Connector shell: aluminum alloy 6061
- Insulator (v): rigid dielectric
- Insulator (m): liquid crystal polymer (LCP) or polyphenylene sulfide (PPS)
- Flange seal: fluorosilicone rubber, blue
- Pin contact: copper alloy, gold over nickel plating
- Socket contact: copper alloy, gold over nickel plating
- Ground spring: stainless steel, gold plating
- Hardware: 300 series stainless steel, passivated
- Encapsulant: epoxy resin hysol EE4215

PERFORMANCE SPECIFICATIONS

- Current rating: 3 amp (Micro-D pins)
- DWV: 600 vac sea level
- Insulation resistance: 5000 megohms minimum
- Operating temperature: -55°C to 150°C
- Mating force (contact m): (10 ounces) x (# of contacts)
- Mating force (contact v): (5 ounces) x (# of contacts)
- Electrical performance IAW Glenair specification GT-19-230
- Interface dimensions IAW MIL-DTL-83513
- Reference application notes AN0005 for optimal performance

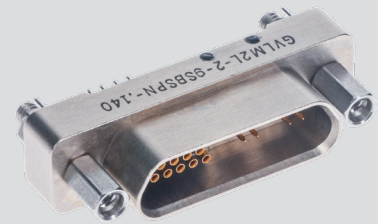
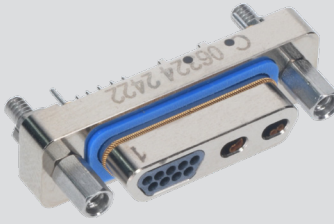

PART NUMBER DEVELOPMENT

Sample Part Number	GVLM	2	L-	2-9	P	BS	PN	-.110
Series	GVLM = VersaLink Micro-D							
Shell Finish	2 = Nickel 5 = Gold							
Insulator Material	L = LCP or PPS							
Contact Layout (V-M)¹	1-0, 1-9, 2-0, 2-9, 2-15, 2-21, 3-9, 4-0, 4-15, 4-31, 8-9, 10-0							
Connector Type⁴	P = Plug S = Receptacle							
Connector Style	BS = Board Straight							
Hardware³ (see mounting hardware table)	N = Thru hole, no hardware installed PN = Extended jackpost with hex nut and lockwasher Rear panel mount jackposts (Length in Inches): R1 = .032 panel R2 = .047 panel R3 = .062 panel R4 = .093 panel R5 = .125 panel R6 = .080 panel L = Hex head jackscrew (non-removable) with threaded insert LU = Hex head jackscrew (non-removable) with thru hole							
PC Tail Length⁵	-.080, -.110, -.140 (Length in Inches +.020/-.000)							

NOTES

1. Refer to GHS4-M-1000 for insert arrangement details on page 90.
2. Refer to GVLM-1000 for GVLM-BS PCB footprints on page 102.
3. Refer to GVLM-1005 details on page 91.
4. Recommended mating dimensions must be maintained when no hardware is used, see page 91.
5. Plug connector uses pin Micro-D contacts and socket VersaLink contacts. Receptacle uses socket Micro-D contacts and pin VersaLink contacts.
6. PC tails are solder-dipped in 60/40 tin-lead solder.
7. Refer to 500-154 for protective cover on page 161.

HARDWARE

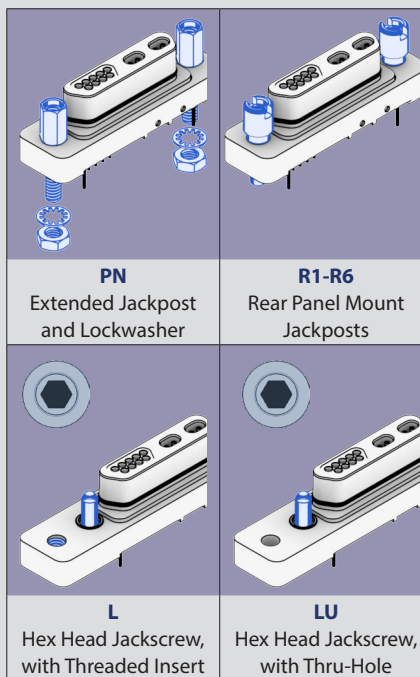

INSERT ARRANGEMENTS

Insert Arrangements	No. of Contacts	
	VersaLink (V)	TwistPin (M)
1-0	1	0
2-0	2	0
1-9	1	9
2-9	2	9
4-0	4	0
2-15	2	15
2-21	2	21
3-9	3	9
4-15	4	15
wa	4	31
8-9	8	9
10-0	10	0

"ZERO-CROSSTALK" M83513 Micro-D VersaLink™ Connectors



GVLM-BS, Straight PCB Connector

GVLM-BS PLUG

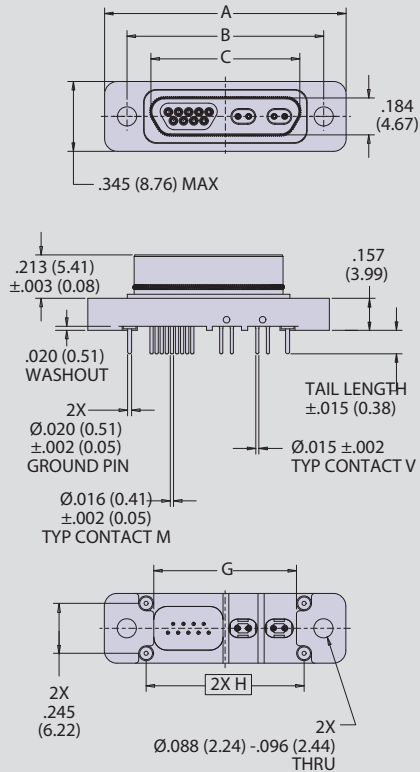

GVLM-BS RECEPTACLE

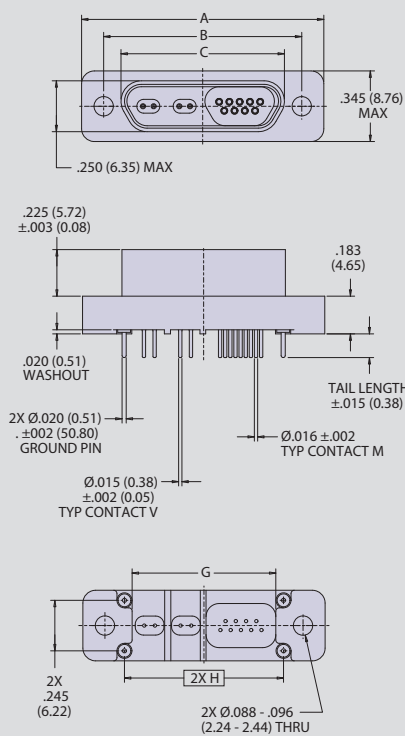

CONNECTOR DIMENSIONS WITH L/LU STYLE HARDWARE ONLY

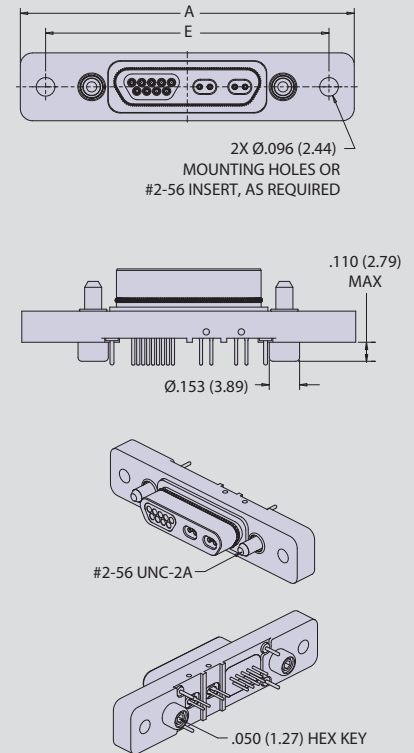

MICRO-D VERSALINK CONNECTORS

PLUG DIMENSIONS

LAYOUT	A MAX	B	C MAX	G	H BSC
1-0P	0.785 (19.94)	0.565 (14.35)	0.333 (8.46)	0.300 (7.62)	0.375 (9.53)
2-0P	0.935 (23.75)	0.715 (18.16)	0.483 (12.27)	0.450 (11.43)	0.525 (13.34)
1-9P	1.085 (27.56)	0.865 (21.97)	0.633 (16.08)	0.600 (15.24)	0.675 (17.15)
2-9P	1.185 (30.10)	0.965 (24.51)	0.733 (18.62)	0.700 (17.78)	0.775 (19.69)
4-0P	1.185 (30.10)	0.965 (24.51)	0.733 (18.62)	0.700 (17.78)	0.775 (19.69)
2-15P	1.335 (33.91)	1.115 (28.32)	0.833 (21.16)	0.850 (21.59)	0.925 (23.50)
2-21P	1.485 (37.72)	1.265 (32.13)	1.033 (26.24)	1.000 (25.40)	1.075 (27.31)
3-9P	1.485 (37.72)	1.265 (32.13)	1.033 (26.24)	1.000 (25.40)	1.075 (27.31)
4-15P	1.835 (46.61)	1.615 (41.02)	1.384 (35.15)	1.350 (34.29)	1.425 (36.20)
4-31P	2.235 (56.77)	2.015 (51.18)	1.784 (45.31)	1.750 (44.45)	1.825 (46.36)
8-9P	2.235 (56.77)	2.015 (51.18)	1.784 (45.31)	1.750 (44.45)	1.825 (46.36)
10-0P	2.235 (56.77)	2.015 (51.18)	1.784 (45.31)	1.750 (44.45)	1.825 (46.36)

RECEPTACLE DIMENSIONS

LAYOUT	A MAX	B	C MAX	G	H BSC
1-0S	0.785 (19.94)	0.565 (14.35)	0.400 (10.16)	0.300 (7.62)	0.375 (9.53)
2-0S	0.935 (23.75)	0.715 (18.16)	0.551 (14.00)	0.450 (11.43)	0.525 (13.34)
1-9S	1.085 (27.56)	0.865 (21.97)	0.701 (17.81)	0.600 (15.24)	0.675 (17.15)
2-9S	1.185 (30.10)	0.965 (24.51)	0.801 (20.35)	0.700 (17.78)	0.775 (19.69)
4-0S	1.185 (30.10)	0.965 (24.51)	0.801 (20.35)	0.700 (17.78)	0.775 (19.69)
2-15S	1.335 (33.91)	1.115 (28.32)	0.951 (24.16)	0.850 (21.59)	0.925 (23.50)
2-21S	1.485 (37.72)	1.265 (32.13)	1.101 (27.97)	1.000 (25.40)	1.075 (27.31)
3-9S	1.485 (37.72)	1.265 (32.13)	1.101 (27.97)	1.000 (25.40)	1.075 (27.31)
4-15S	1.835 (46.61)	1.615 (41.02)	1.450 (36.83)	1.350 (34.29)	1.425 (36.20)
4-31S	2.235 (56.77)	2.015 (51.18)	1.850 (46.99)	1.750 (44.45)	1.825 (46.36)
8-9S	2.235 (56.77)	2.015 (51.18)	1.850 (46.99)	1.750 (44.45)	1.825 (46.36)
10-0S	2.235 (56.77)	2.015 (51.18)	1.850 (46.99)	1.750 (44.45)	1.825 (46.36)

L/LU DIMENSIONS

Layout	A MAX	E ±.005
1-0	1.285 (32.64)	1.030 (26.16)
2-0	1.435 (36.45)	1.180 (29.97)
1-9	1.585 (40.26)	1.330 (33.78)
2-9	1.685 (42.80)	1.430 (36.32)
4-0	1.685 (42.80)	1.430 (36.32)
2-15	1.835 (46.61)	1.580 (40.13)
2-21	1.985 (50.42)	1.730 (43.94)
3-9	1.985 (50.42)	1.730 (43.94)
4-15	2.335 (59.31)	2.080 (52.83)
4-31	2.735 (69.47)	2.480 (62.99)
8-9	2.735 (69.47)	2.480 (62.99)
10-0	2.735 (69.47)	2.480 (62.99)

"ZERO-CROSSTALK" M83513 Micro-D VersaLink™ Connectors



GVLM-1000: GVLM-BS, Straight PCB Connector Footprints, VersaLink PCB Layout

MICRO-D VERSALINK CONNECTORS

Plug Layout 1-0

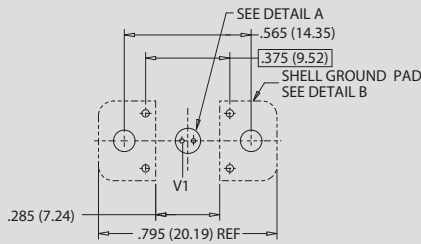

JACKPOST HARDWARE (P and R1 -R6)

Receptacle Layout 1-0

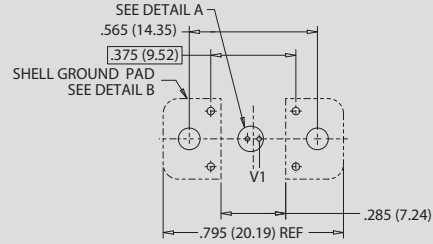

JACKPOST HARDWARE (P and R1 -R6)

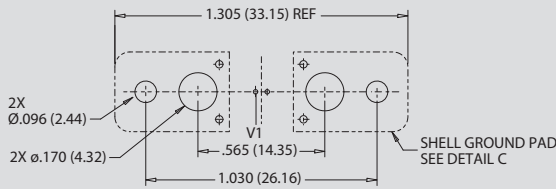

JACKSCREW HARDWARE (L/LU)

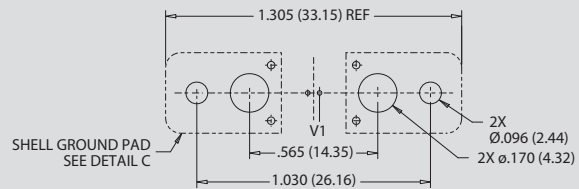

JACKSCREW HARDWARE (L/LU)

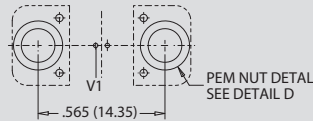

REAR PANEL MOUNT JACKPOSTS
WHEN USING PEM NUT (R1 THRU R6)

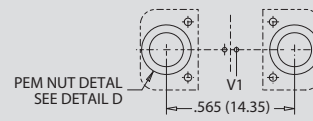

REAR PANEL MOUNT JACKPOSTS
WHEN USING PEM NUT (R1 THRU R6)

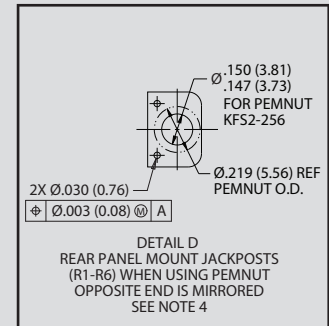
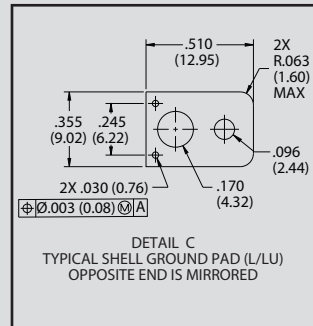
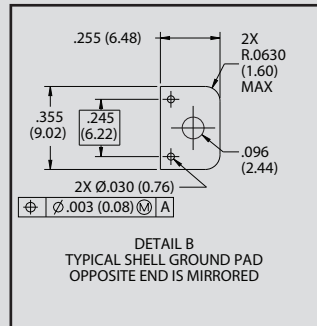
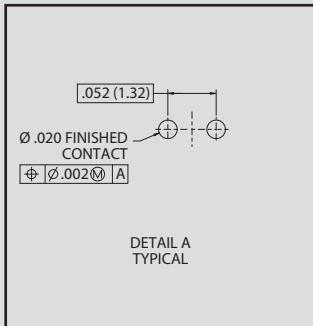

NOTES

1. Patterns shown are for connector mounting side of PC board.
2. Reference GVLM-BS for connector details.
3. Reference application notes AN0005 for optimal performance.
4. Pennuts are the recommended solution for rear panel mount hardware. When using loose nuts to secure to panel, use the same footprint as the "P" hardware option shown in Detail B.

"ZERO-CROSSTALK" M83513 Micro-D VersaLink™ Connectors



GVLM-1000: GVLM-BS, Straight PCB Connector Footprints, VersaLink PCB Layout

Plug Layout 2-0

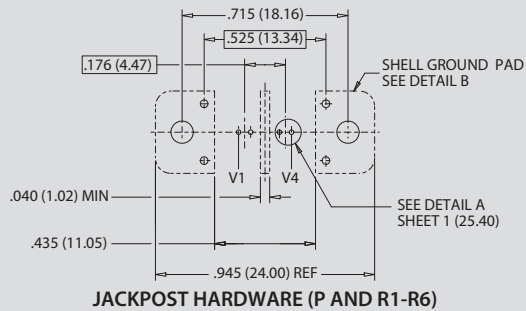

Receptacle Layout 2-0

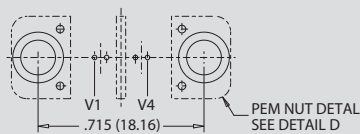
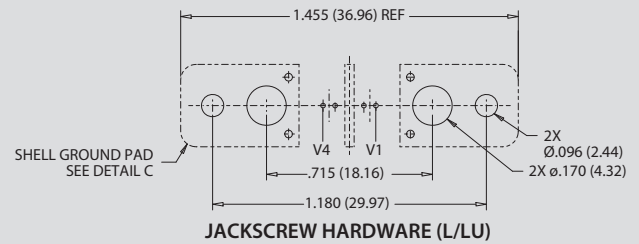
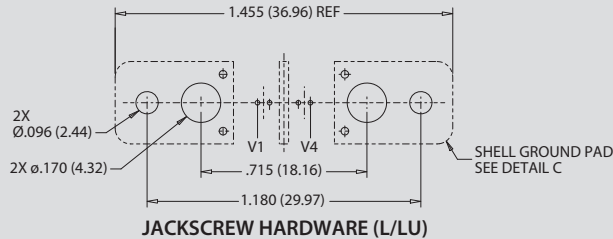
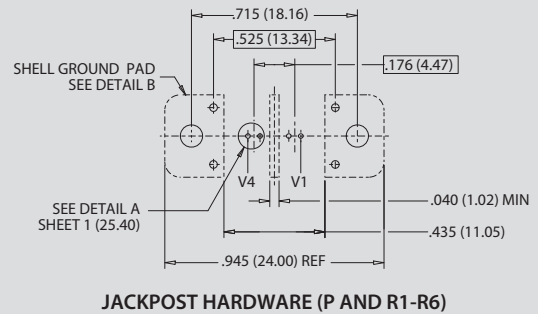

REAR PANEL MOUNT JACKPOSTS
WHEN USING PEM NUT (R1 THRU R6)

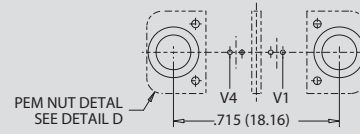

REAR PANEL MOUNT JACKPOSTS
WHEN USING PEM NUT (R1 THRU R6)

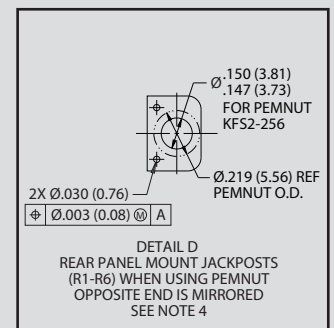
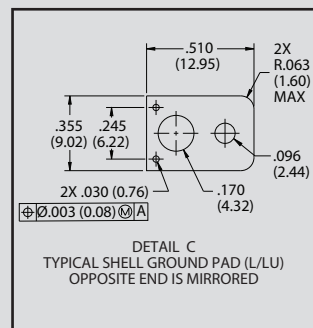
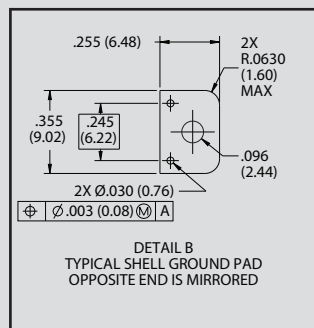
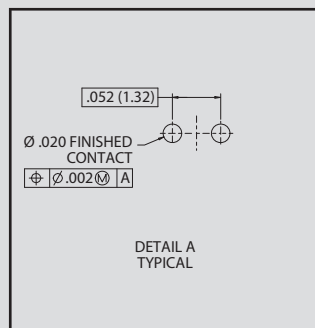

NOTES

1. Patterns shown are for connector mounting side of PC board.
2. Reference GVLM-BS for connector details.
3. Reference application notes AN0005 for optimal performance.
4. Pemnuts are the recommended solution for rear panel mount hardware. When using loose nuts to secure to panel, use the same footprint as the "P" hardware option shown in Detail B.

"ZERO-CROSSTALK" M83513 Micro-D VersaLink™ Connectors



GVLM-1000: GVLM-BS, Straight PCB Connector Footprints, VersaLink PCB Layout

MICRO-D VERSALINK CONNECTORS

Plug Layout 4-0

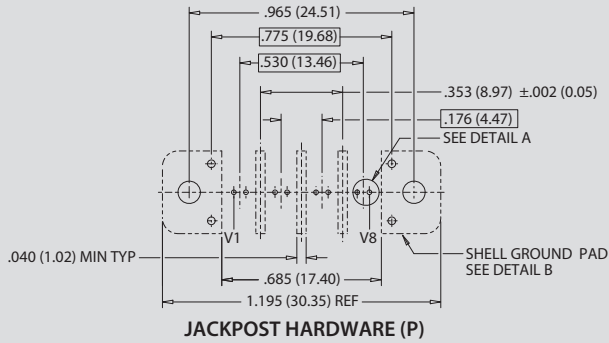

Receptacle Layout 4-0

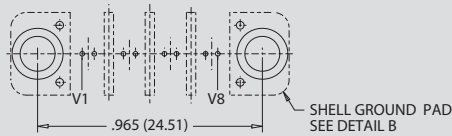
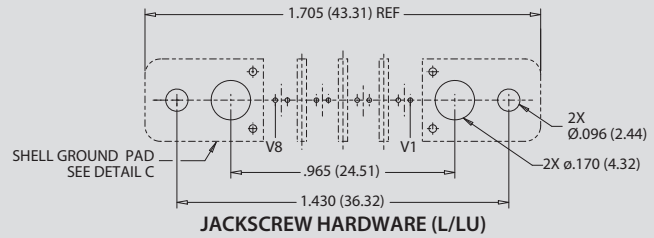
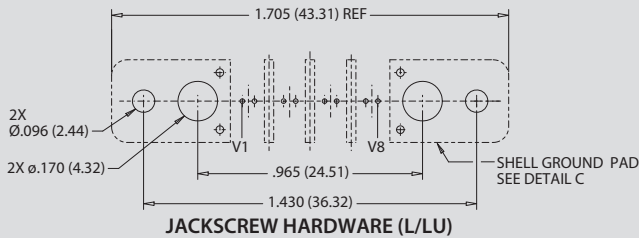
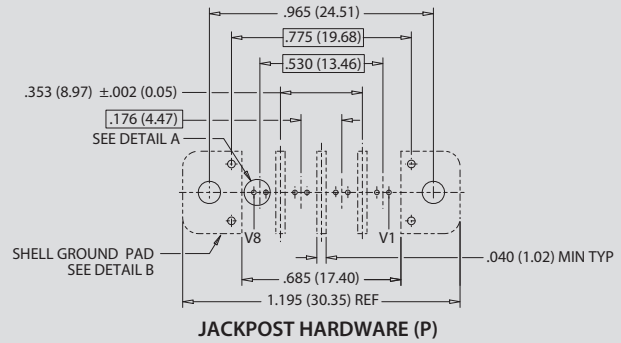

REAR PANEL MOUNT JACKPOSTS
WHEN USING PEM NUT (R1 THRU R6)

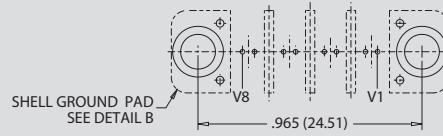

REAR PANEL MOUNT JACKPOSTS
WHEN USING PEM NUT (R1 THRU R6)

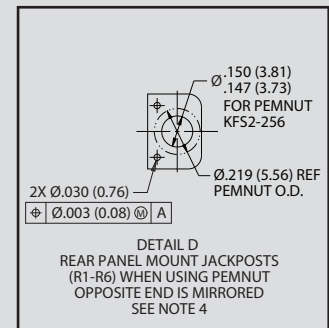
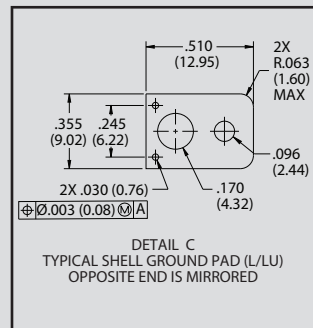
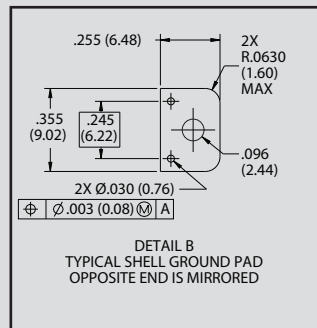
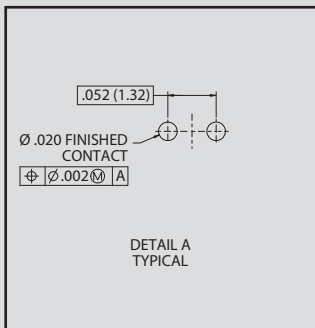

NOTES

1. Patterns shown are for connector mounting side of PC board.
2. Reference GVLM-BS for connector details.
3. Reference application notes AN0005 for optimal performance.
4. Pemnuts are the recommended solution for rear panel mount hardware. When using loose nuts to secure to panel, use the same footprint as the "P" hardware option shown in Detail B.

"ZERO-CROSSTALK" M83513 Micro-D VersaLink™ Connectors



GVLM-1000: GVLM-BS, Straight PCB Connector Footprints, VersaLink PCB Layout

Plug Layout 10-0

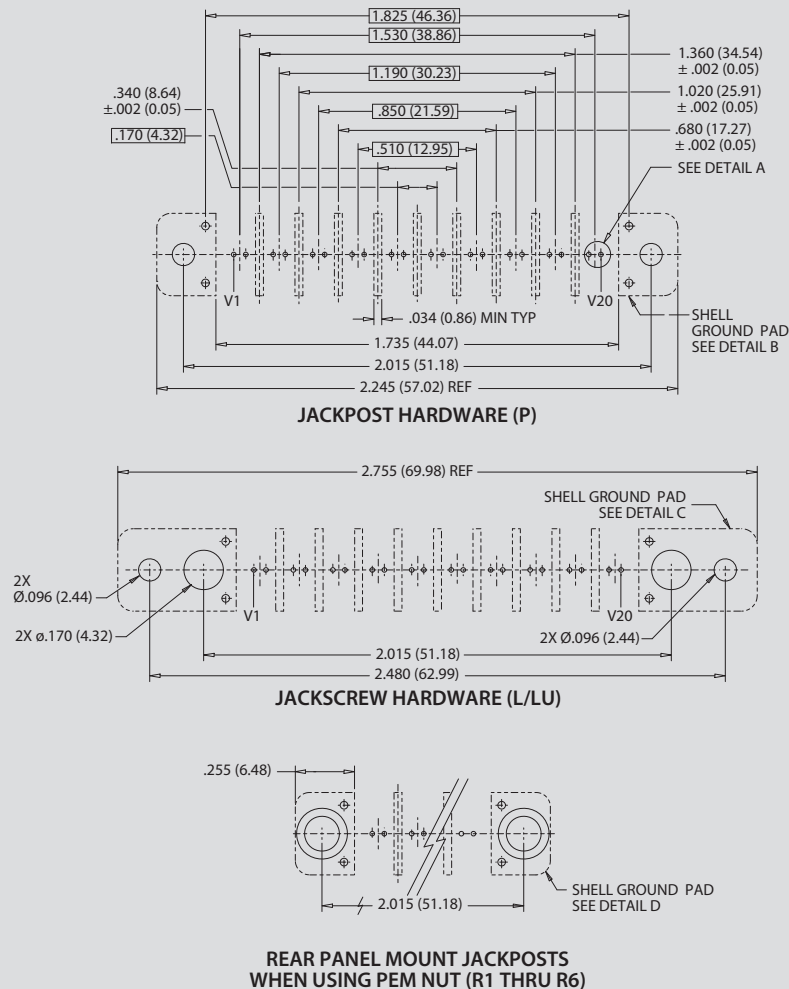

MICRO-D VERSALINK CONNECTORS

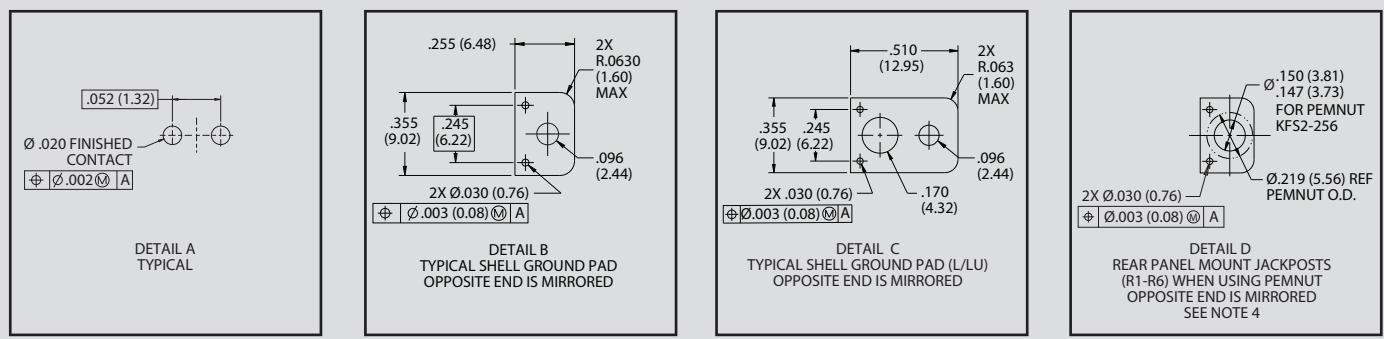

NOTES

1. Patterns shown are for connector mounting side of PC board.
2. Reference GVLM-BS for connector details.
3. Reference application notes AN0005 for optimal performance.
4. Pemnuts are the recommended solution for rear panel mount hardware. When using loose nuts to secure to panel, use the same footprint as the "P" hardware option shown in Detail B.

"ZERO-CROSSTALK" M83513 Micro-D VersaLink™ Connectors



GVLM-1000: GVLM-BS, Straight PCB Connector Footprints, VersaLink PCB Layout

MICRO-D VERSALINK CONNECTORS

Receptacle Layout 10-0

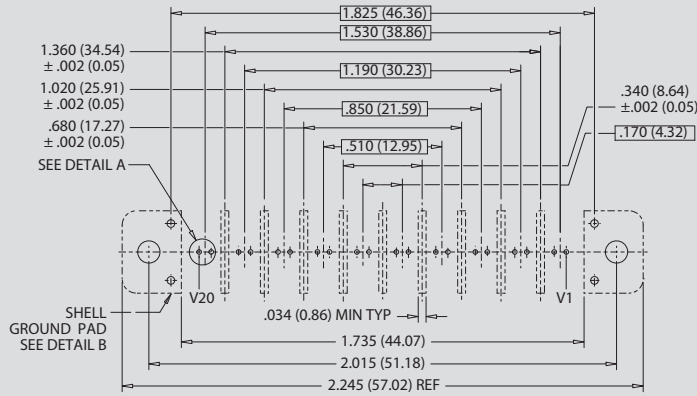

JACKPOST HARDWARE (P)

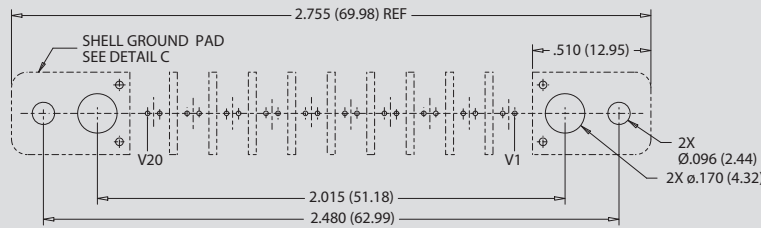

JACKSCREW HARDWARE (L/LU)

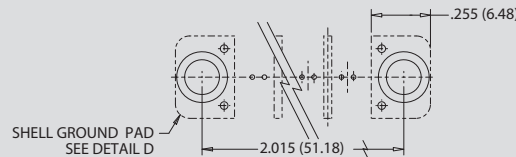

REAR PANEL MOUNT JACKPOSTS
WHEN USING PEM NUT (R1 THRU R6)

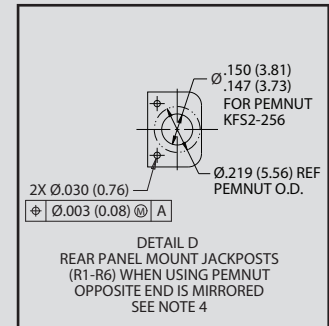
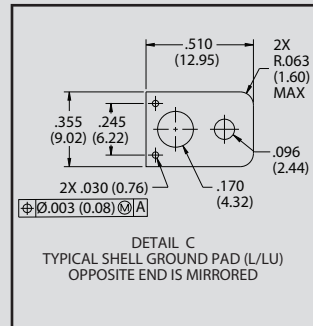
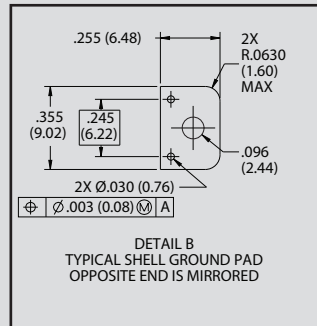
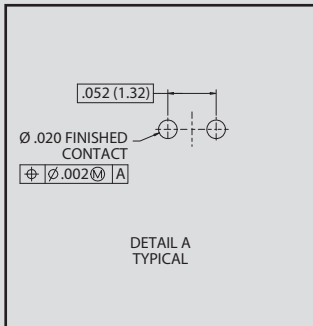

NOTES

1. Patterns shown are for connector mounting side of PC board.
2. Reference GVLM-BS for connector details.
3. Reference application notes AN0005 for optimal performance.
4. Pemnuts are the recommended solution for rear panel mount hardware. When using loose nuts to secure to panel, use the same footprint as the "P" hardware option shown in Detail B.

"ZERO-CROSSTALK" M83513 Micro-D VersaLink™ Connectors



GVLM-1000: GVLM-BS, Straight PCB Connector Footprints, VersaLink PCB Layout

Plug Layout 1-9

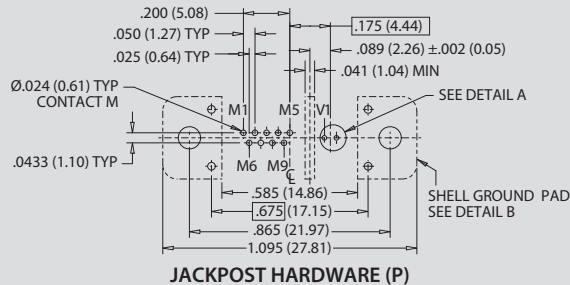

Receptacle Layout 1-9

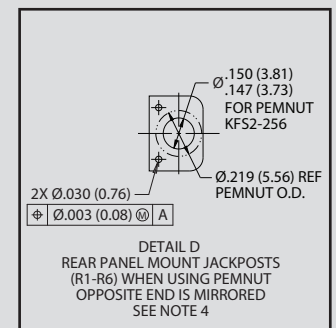
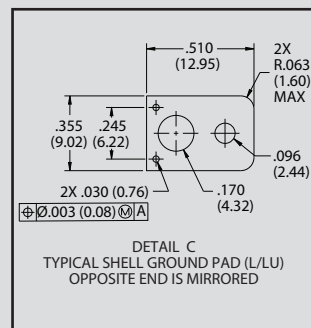
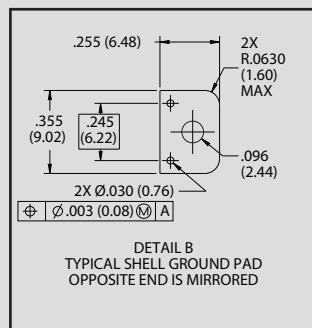
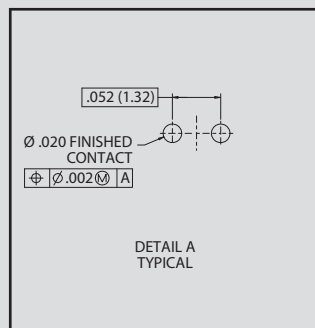
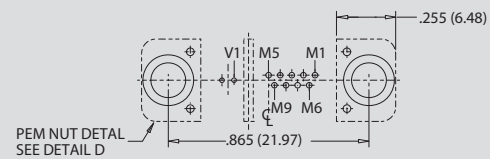
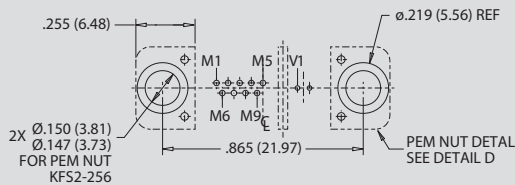
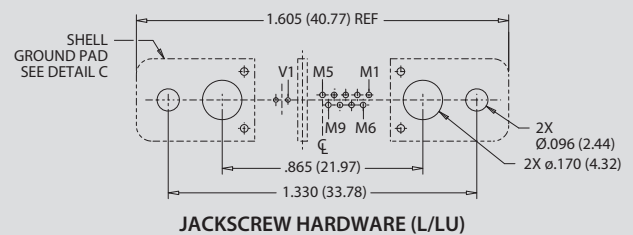
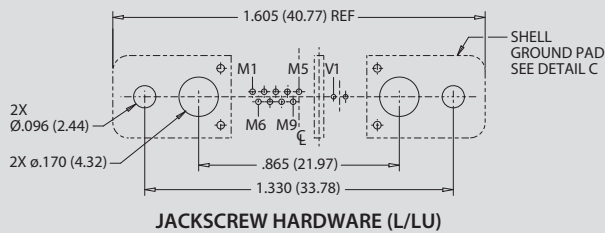
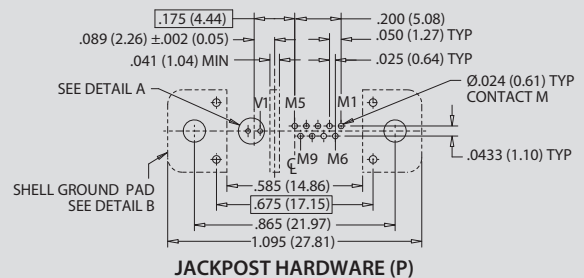

NOTES

1. Patterns shown are for connector mounting side of PC board.
2. Reference GVLM-BS for connector details.
3. Reference application notes AN0005 for optimal performance.
4. Pemnuts are the recommended solution for rear panel mount hardware. When using loose nuts to secure to panel, use the same footprint as the "P" hardware option shown in Detail B.

"ZERO-CROSSTALK" M83513 Micro-D VersaLink™ Connectors



GVLM-1000: GVLM-BS, Straight PCB Connector Footprints, VersaLink PCB Layout

MICRO-D VERSALINK CONNECTORS

Plug Layout 2-9

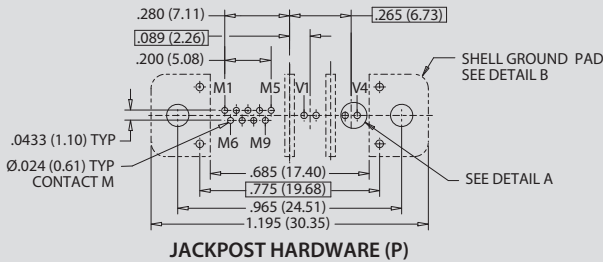

Receptacle Layout 2-9

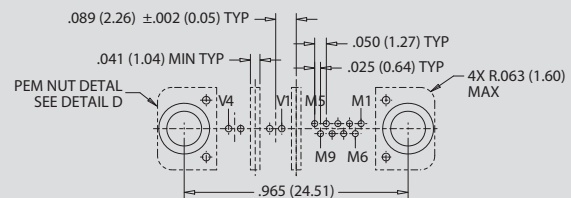
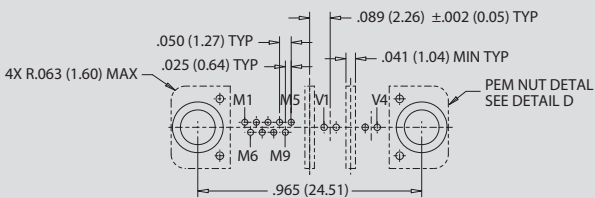
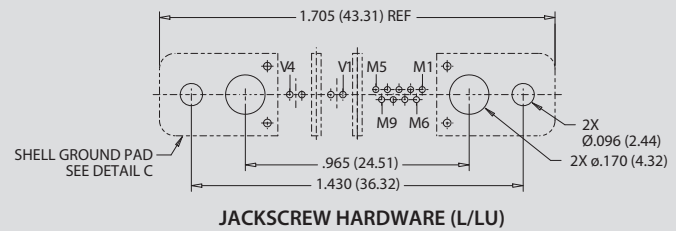
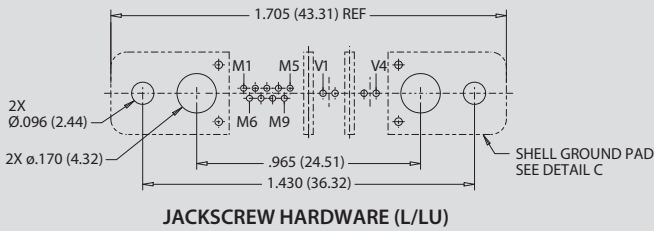
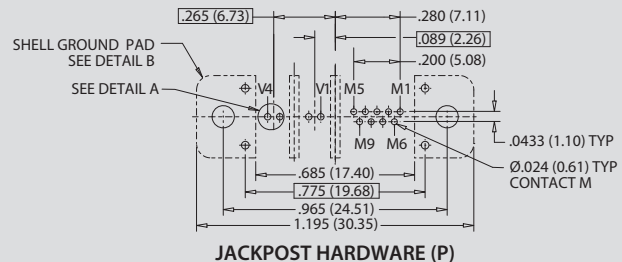

REAR PANEL MOUNT JACKPOSTS
WHEN USING PEM NUT (R1 THRU R6)

REAR PANEL MOUNT JACKPOSTS
WHEN USING PEM NUT (R1 THRU R6)

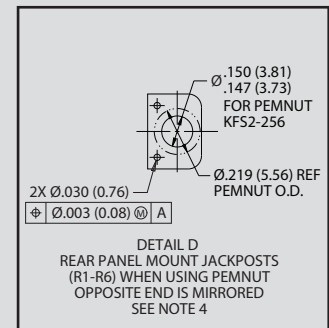
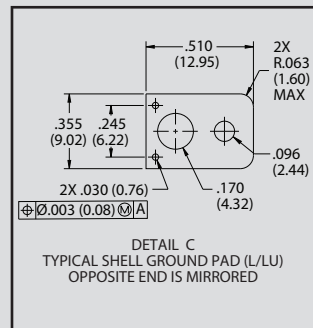
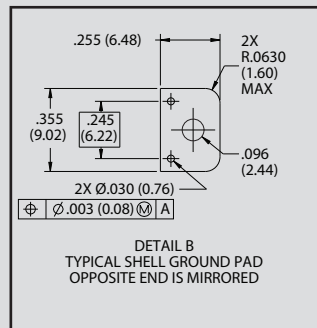
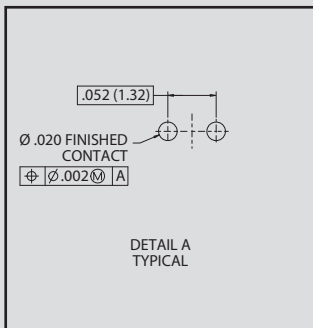

NOTES

1. Patterns shown are for connector mounting side of PC board.
2. Reference GVLM-BS for connector details.
3. Reference application notes AN0005 for optimal performance.
4. Pemnuts are the recommended solution for rear panel mount hardware. When using loose nuts to secure to panel, use the same footprint as the "P" hardware option shown in Detail B.

"ZERO-CROSSTALK" M83513 Micro-D VersaLink™ Connectors



GVLM-1000: GVLM-BS, Straight PCB Connector Footprints, VersaLink PCB Layout

Plug Layout 2-15

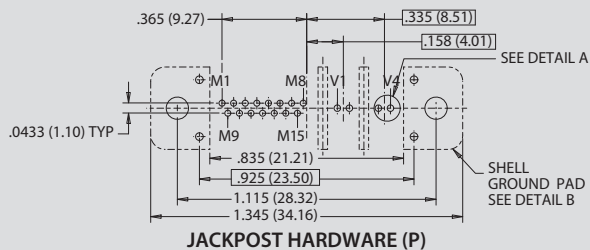

Receptacle Layout 2-15

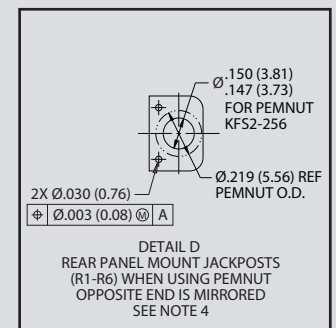
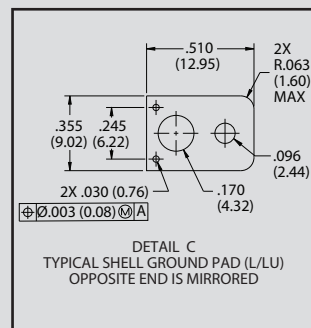
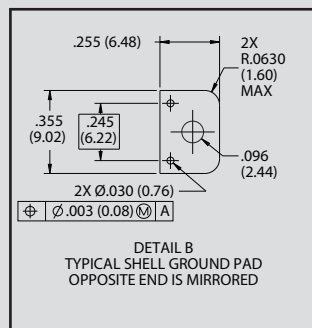
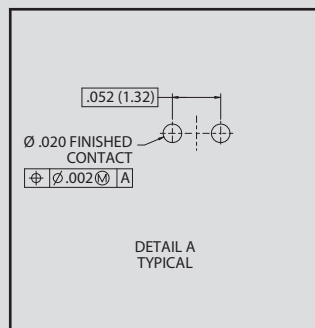
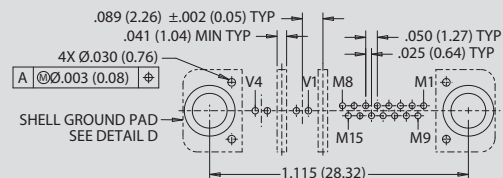
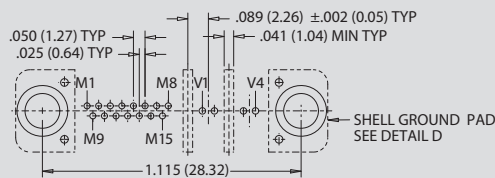
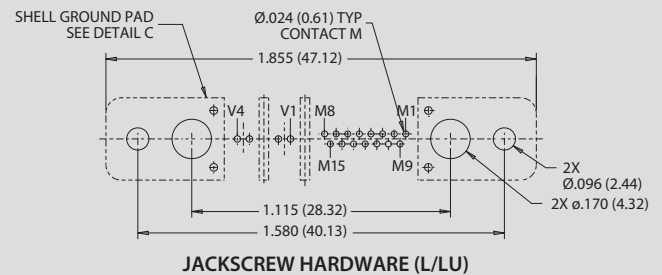
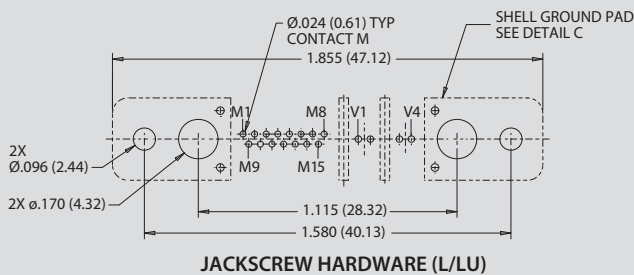
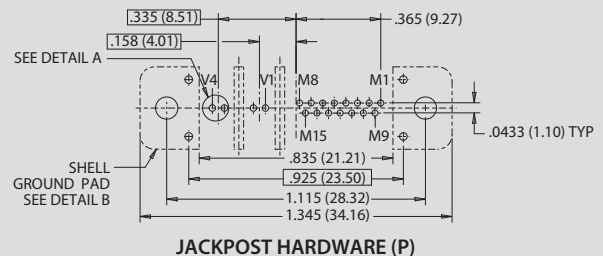

NOTES

1. Patterns shown are for connector mounting side of PC board.
2. Reference GVLM-BS for connector details.
3. Reference application notes AN0005 for optimal performance.
4. Pemnuts are the recommended solution for rear panel mount hardware. When using loose nuts to secure to panel, use the same footprint as the "P" hardware option shown in Detail B.

"ZERO-CROSSTALK" M83513 Micro-D VersaLink™ Connectors



GVLM-1000: GVLM-BS, Straight PCB Connector Footprints, VersaLink PCB Layout

MICRO-D VERSALINK CONNECTORS

Plug Layout 2-21

Receptacle Layout 2-21

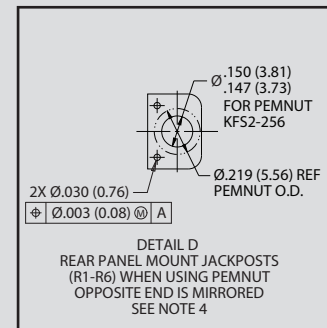
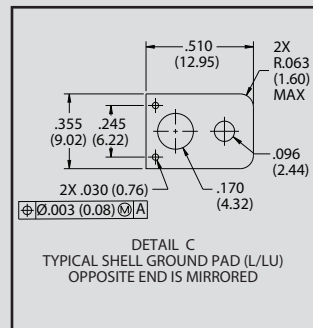
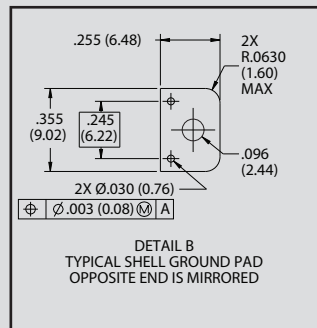
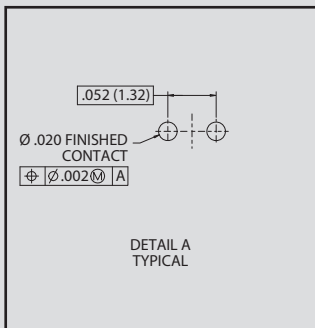
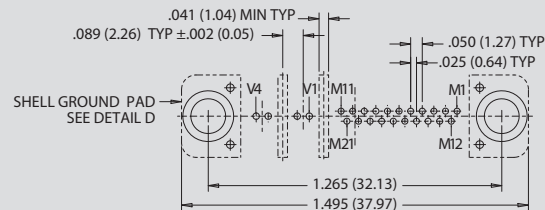
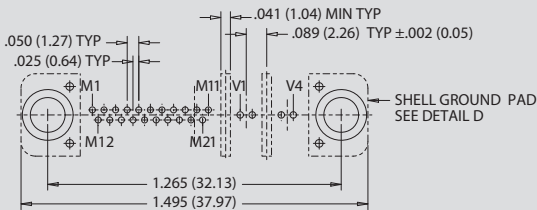
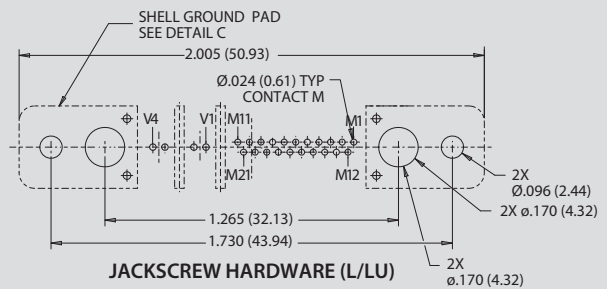
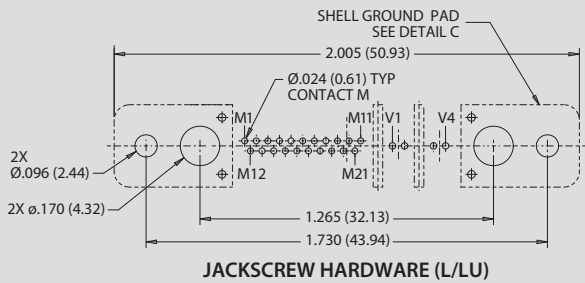
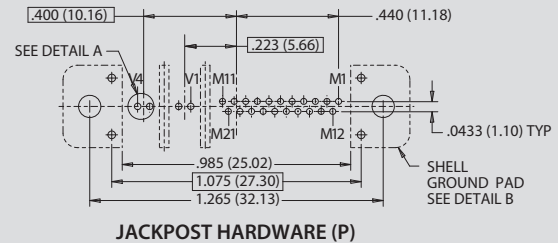
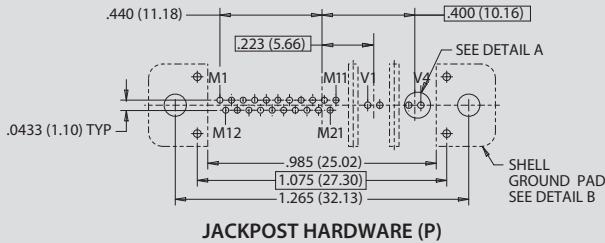

NOTES

1. Patterns shown are for connector mounting side of PC board.
2. Reference GVLM-BS for connector details.
3. Reference application notes AN0005 for optimal performance.
4. Pemnuts are the recommended solution for rear panel mount hardware. When using loose nuts to secure to panel, use the same footprint as the "P" hardware option shown in Detail B.

"ZERO-CROSSTALK" M83513 Micro-D VersaLink™ Connectors



GVLM-1000: GVLM-BS, Straight PCB Connector Footprints, VersaLink PCB Layout

Plug Layout 3-9

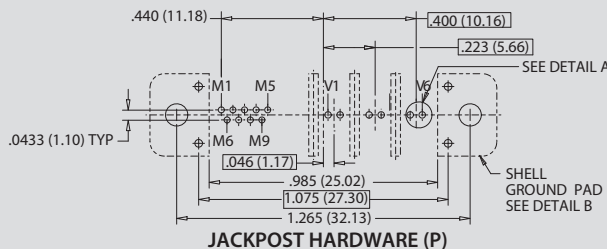

Receptacle Layout 3-9

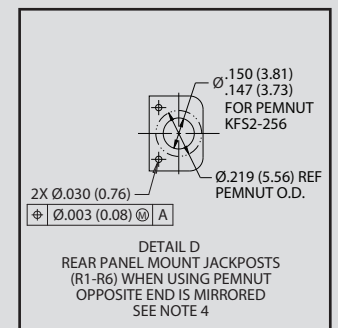
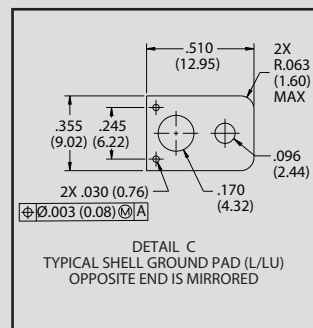
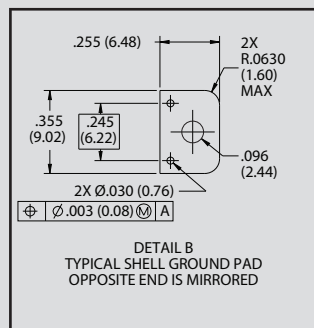
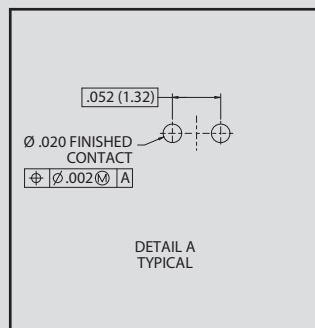
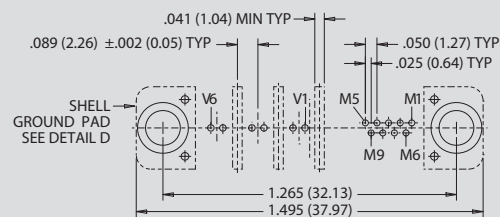
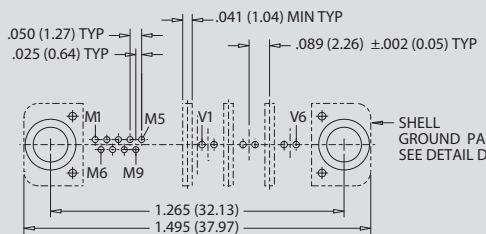
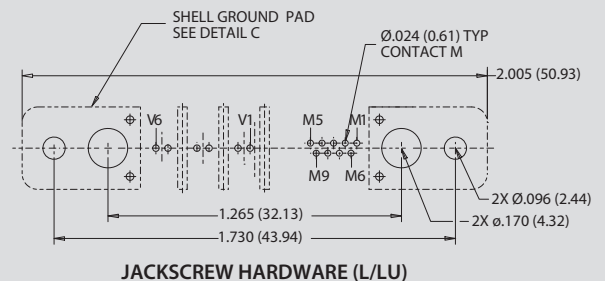
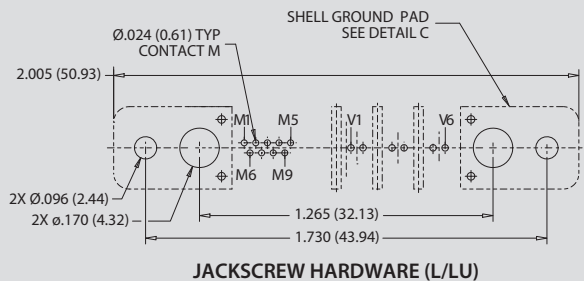
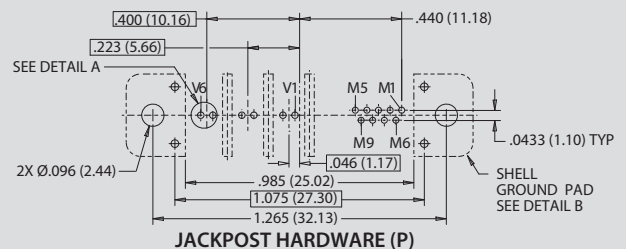

NOTES

1. Patterns shown are for connector mounting side of PC board.
2. Reference GVLM-BS for connector details.
3. Reference application notes AN0005 for optimal performance.
4. Pemnuts are the recommended solution for rear panel mount hardware. When using loose nuts to secure to panel, use the same footprint as the "P" hardware option shown in Detail B.

"ZERO-CROSSTALK" M8513 Micro-D VersaLink™ Connectors



GVLM-1000: GVLM-BS, Straight PCB Connector Footprints, VersaLink PCB Layout

MICRO-D VERSALINK CONNECTORS

Plug Layout 4-15

Receptacle Layout 4-15

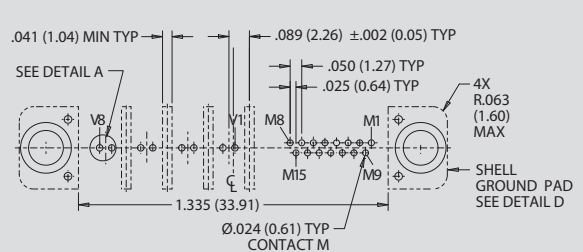
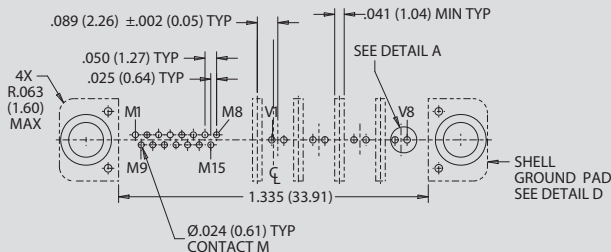
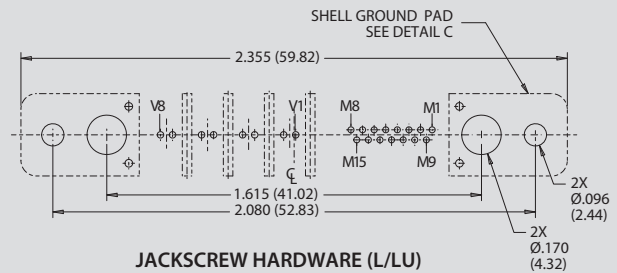
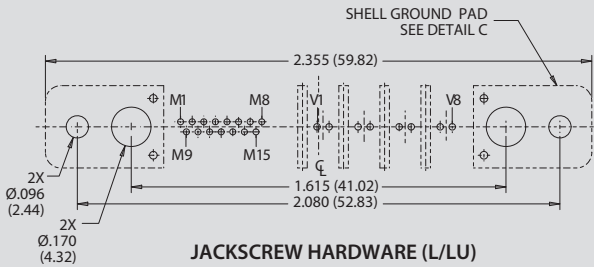
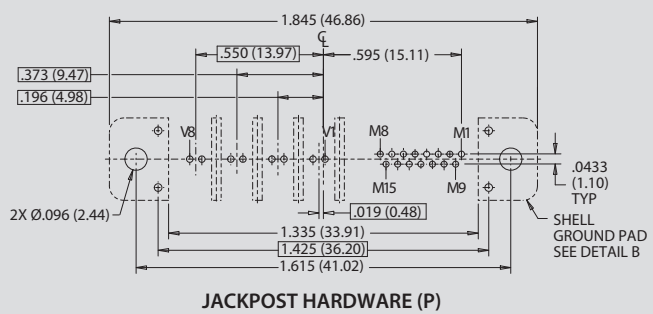
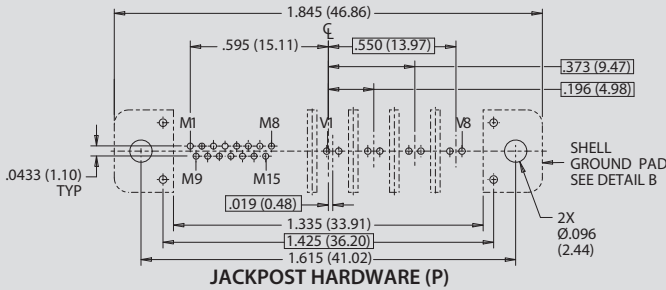

REAR PANEL MOUNT JACKPOSTS
WHEN USING PEM NUT (R1 THRU R6)

REAR PANEL MOUNT JACKPOSTS
WHEN USING PEM NUT (R1 THRU R6)

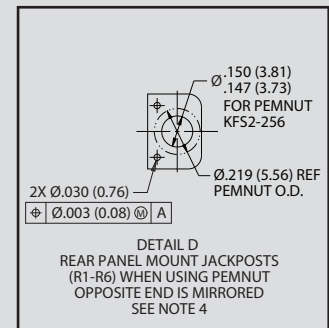
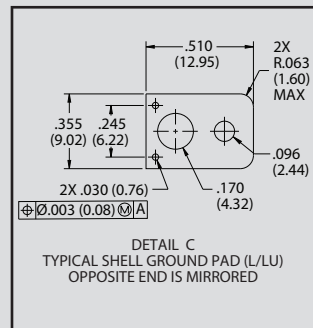
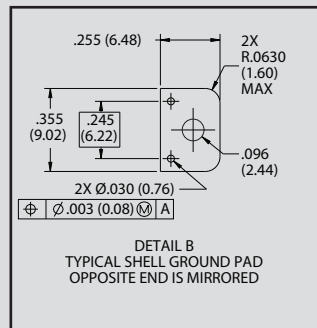
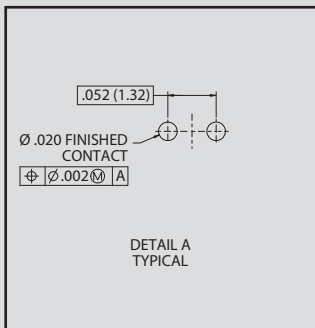

NOTES

- Patterns shown are for connector mounting side of PC board.
- Reference GVLM-BS for connector details.
- Reference application notes AN0005 for optimal performance.
- Pemnuts are the recommended solution for rear panel mount hardware. When using loose nuts to secure to panel, use the same footprint as the "P" hardware option shown in Detail B.

"ZERO-CROSSTALK" M83513 Micro-D VersaLink™ Connectors



GVLM-1000: GVLM-BS, Straight PCB Connector Footprints, VersaLink PCB Layout

Plug Layout 4-31

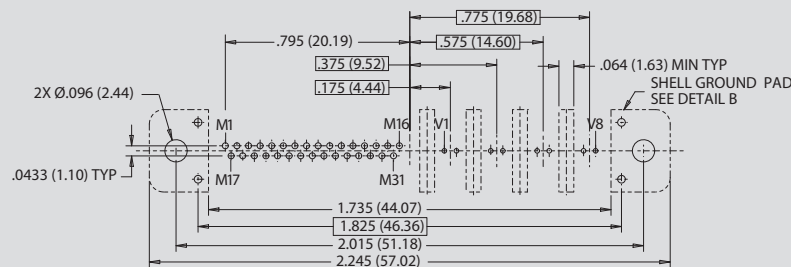

JACKPOST HARDWARE (P)

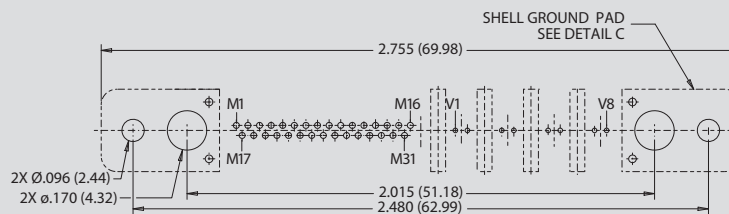

JACKSCREW HARDWARE (L/LU)

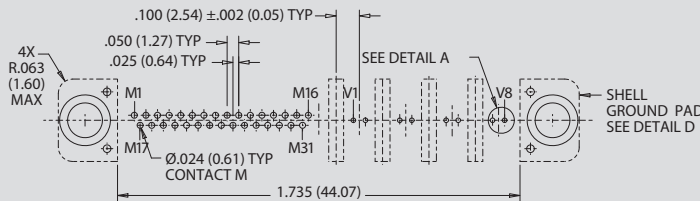

REAR PANEL MOUNT JACKPOSTS
WHEN USING PEM NUT (R1 THRU R6)

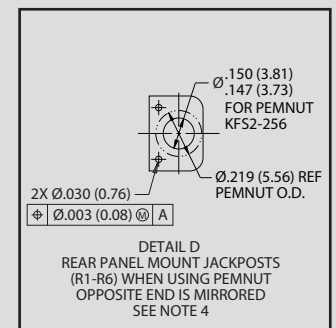
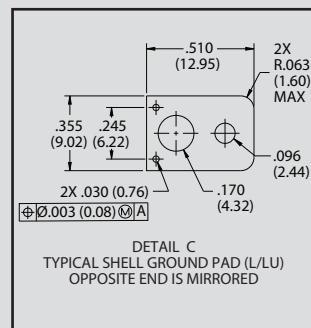
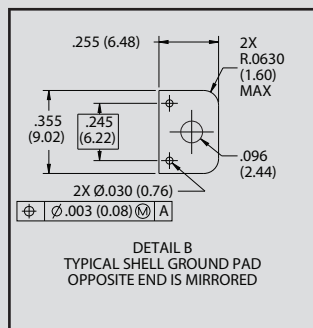
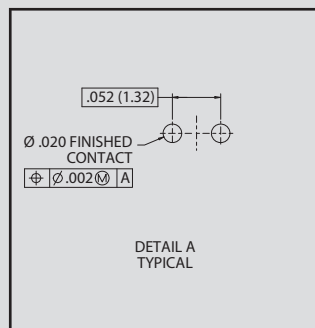

NOTES

1. Patterns shown are for connector mounting side of PC board.
2. Reference GVLM-BS for connector details.
3. Reference application notes AN0005 for optimal performance.
4. Pennuts are the recommended solution for rear panel mount hardware. When using loose nuts to secure to panel, use the same footprint as the "P" hardware option shown in Detail B.

"ZERO-CROSSTALK" M83513 Micro-D VersaLink™ Connectors



GVLM-1000: GVLM-BS, Straight PCB Connector Footprints, VersaLink PCB Layout

MICRO-D VERSALINK CONNECTORS

Receptacle Layout 4-31

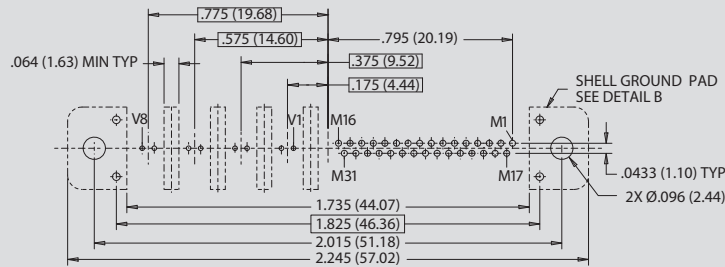

JACKPOST HARDWARE (P)

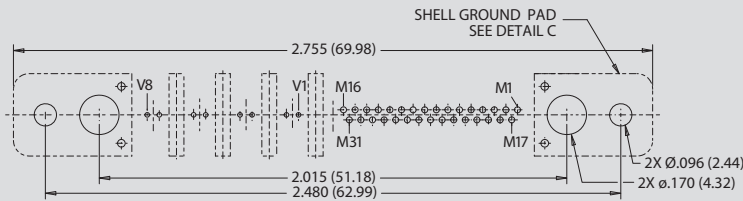

JACKSCREW HARDWARE (L/LU)

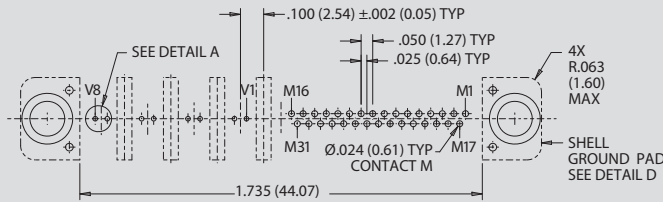

REAR PANEL MOUNT JACKPOSTS WHEN USING PEM NUT (R1 THRU R6)

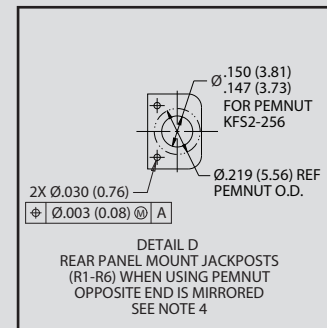
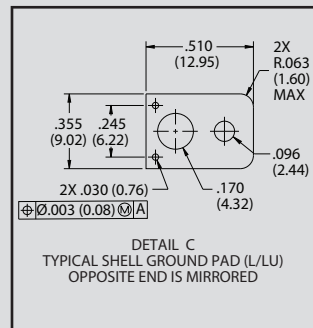
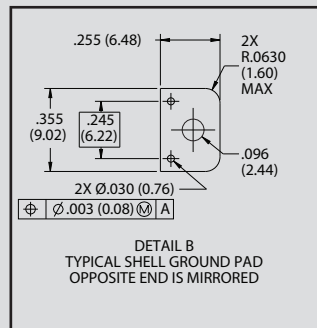
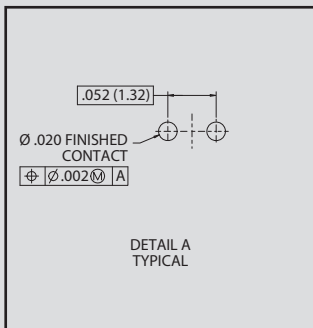

NOTES

1. Patterns shown are for connector mounting side of PC board.
2. Reference GVLM-BS for connector details.
3. Reference application notes AN0005 for optimal performance.
4. Pemnuts are the recommended solution for rear panel mount hardware. When using loose nuts to secure to panel, use the same footprint as the "P" hardware option shown in Detail B.

"ZERO-CROSSTALK" M83513 Micro-D VersaLink™ Connectors



GVLM-1000: GVLM-BS, Straight PCB Connector Footprints, VersaLink PCB Layout

Plug Layout 8-9

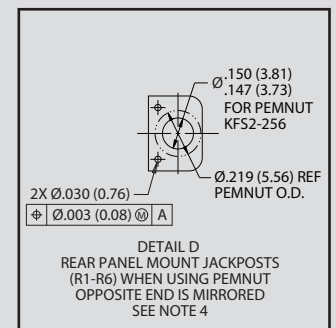
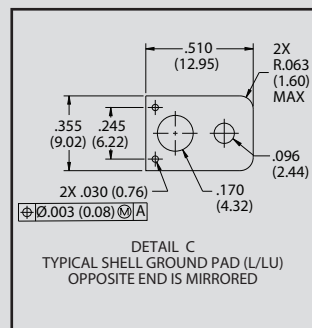
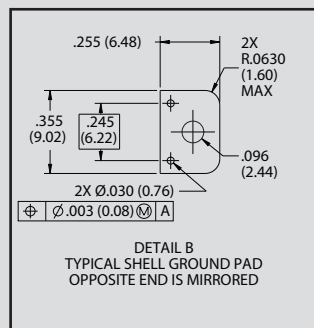
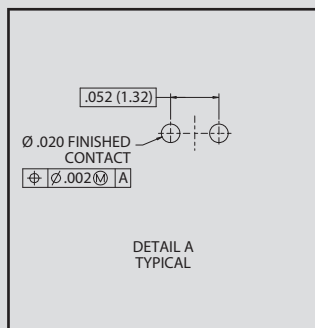
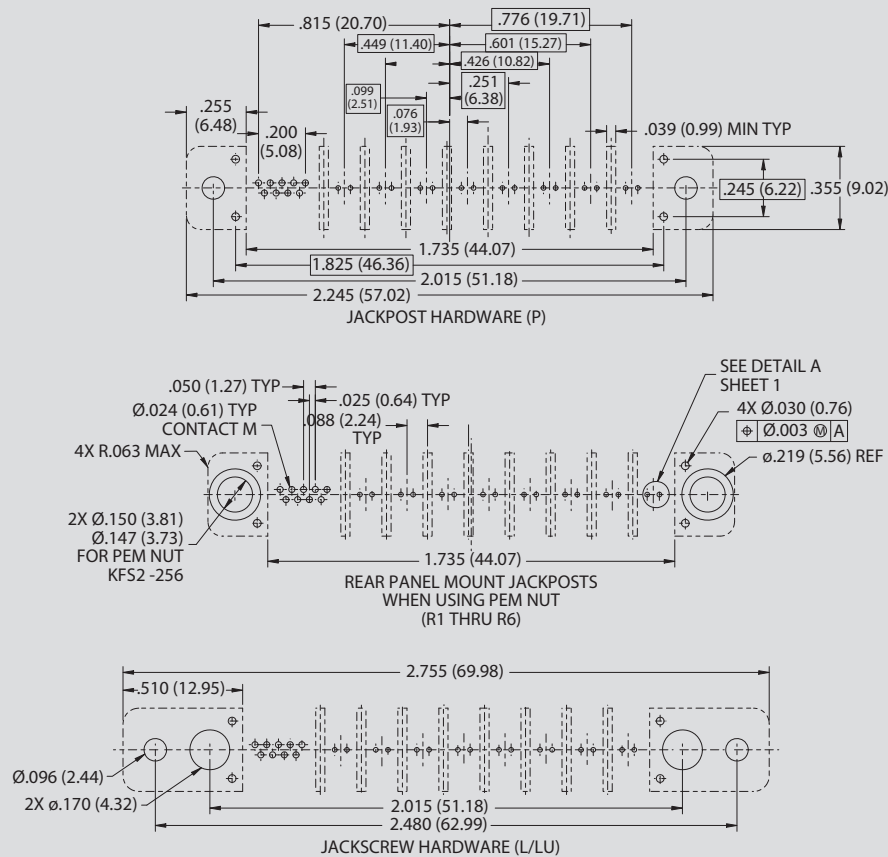

NOTES

1. Patterns shown are for connector mounting side of PC board.
2. Reference GVLM-BS for connector details.
3. Reference application notes AN0005 for optimal performance.
4. Pennuts are the recommended solution for rear panel mount hardware. When using loose nuts to secure to panel, use the same footprint as the "P" hardware option shown in Detail B.

"ZERO-CROSSTALK" M83513 Micro-D VersaLink™ Connectors



GVLM-1000: GVLM-BS, Straight PCB Connector Footprints, VersaLink PCB Layout

MICRO-D VERSALINK CONNECTORS

Receptacle Layout 8-9

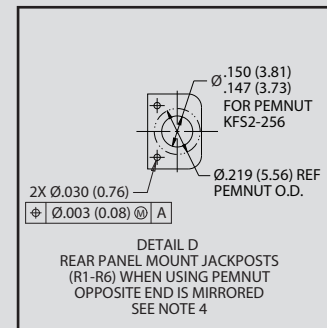
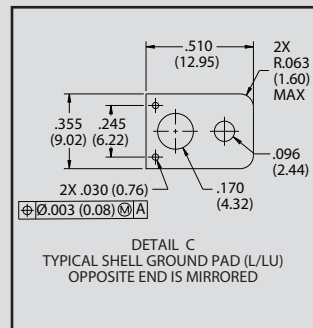
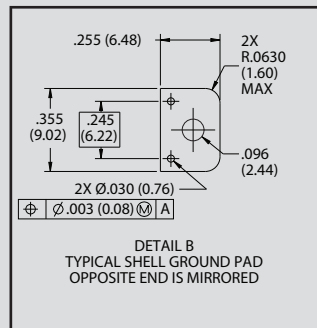
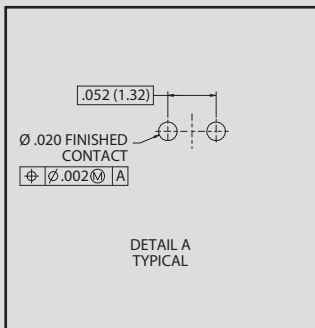
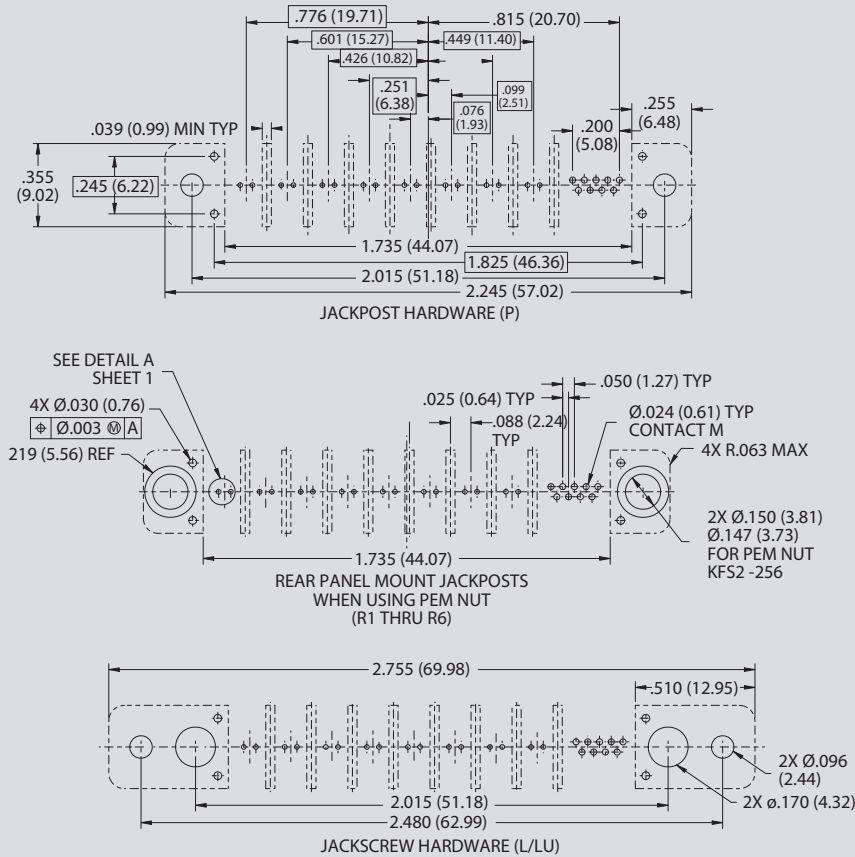

NOTES

1. Patterns shown are for connector mounting side of PC board.
2. Reference GVLM-BS for connector details.
3. Reference application notes AN0005 for optimal performance.
4. Pemnuts are the recommended solution for rear panel mount hardware. When using loose nuts to secure to panel, use the same footprint as the "P" hardware option shown in Detail B.