

# "ZERO-CROSSTALK" M83513 Micro-D VersaLink™ Connectors



## GVLMS-BS, Board Mount Straight, Shielded Connectors

### MATERIALS AND FINISHES

- Connector shell: aluminum alloy 6061
- Insulator (v): rigid dielectric
- Insulator (m): liquid crystal polymer (LCP) or polyphenylene sulfide (PPS)
- Flange seal: fluorosilicone rubber, blue
- Pin contact: copper alloy, gold over nickel plating
- Socket contact: copper alloy, gold over nickel plating
- Ground spring: stainless steel, gold plating
- Hardware: 300 series stainless steel, passivated
- Encapsulant: epoxy resin Hysol EE4215

### PERFORMANCE SPECIFICATIONS

- Current rating: 3 amp (Micro-D pins)
- DWV: 600 VAC sea level
- Insulation resistance: 5000 megohms minimum
- Operating temperature: -55°C to 150°C
- Mating force (contact m): (10 ounces) x (# of contacts)
- Mating force (contact v): (5 ounces) x (# of contacts)
- Electrical performance IAW Glenair specification GT-19-230
- Reference application notes AN0005 for optimal performance

### NOTES

1. Refer to GHS4-MS-1000 for insert arrangement details on page 90.
2. Refer to GVLMS-1000 for GVLMS-BS for shielded PCB footprint details on page 149.
3. connector uses pin Micro-D contacts and socket VersaLink contacts. Receptacle uses socket Micro-D contacts and pin VersaLink contacts.
4. Refer to GVLMS-1005 for panel cutout details on page 91.
5. Connectors are solder-dipped in 60/40 tin-lead solder.
6. GVLMS-BS connectors only mate with GHS4-MS and other ground isolated VersaLink Micro-D connectors.

PART NUMBER DEVELOPMENT								
<b>Sample Part Number</b>	<b>GVLMS</b>	<b>2</b>	<b>L-</b>	<b>2-13</b>	<b>P</b>	<b>BS</b>	<b>PN</b>	<b>-.110</b>
<b>Series</b>	GVLMS = Shielded, Board Mount VersaLink							
<b>Shell Finish</b>	2 = Nickel 5 = Gold							
<b>Insulator Material</b>	L = LCP or PPS							
<b>Contact Layout (V-M)<sup>1</sup></b>	2-0, 2-13, 4-0, 4-25, 8-0							
<b>Connector Type<sup>2</sup></b>	P = Plug S = Receptacle							
<b>Termination Type</b>	BS = Board Straight							
<b>Hardware<sup>4</sup></b>	N = Thru Hole, No Hardware Installed PN = Extended Jackpost with Hex Nut and Lockwasher							
	Rear Panel Jackposts: R1 = .032 panel R2 = .047 panel R3 = .062 panel R4 = .093 panel R5 = .125 panel R6 = .080 panel							
	L = Hex Head Jackscrew (Non-Removable) with Threaded Insert LU = Hex Head Jackscrew (Non-Removable) with Thru Hole							
<b>PC Tail Length<sup>5</sup></b>	.080, .110, .140 (Length in Inches +.020/-000)							

### GVLMS-BS L/LU HARDWARE

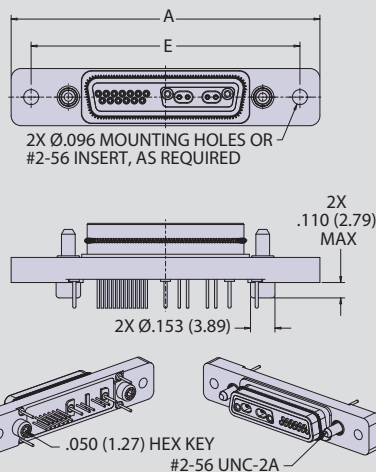

Layout	A Max	E
2-0	1.538 (39.07)	1.282 (32.56)
2-13	1.936 (49.17)	1.680 (42.67)
4-0	1.936 (49.17)	1.680 (42.67)
4-25	2.800 (71.12)	2.559 (65.00)
8-0	2.800 (71.12)	2.559 (65.00)

### INSERT ARRANGEMENTS

Insert Arrangements	No. of Contacts	
	VersaLink (V)	TwistPin (M)
2-0	2	0
2-13	2	13
4-0	4	0
4-25	4	25
8-0	8	0

### MOUNTING HARDWARE

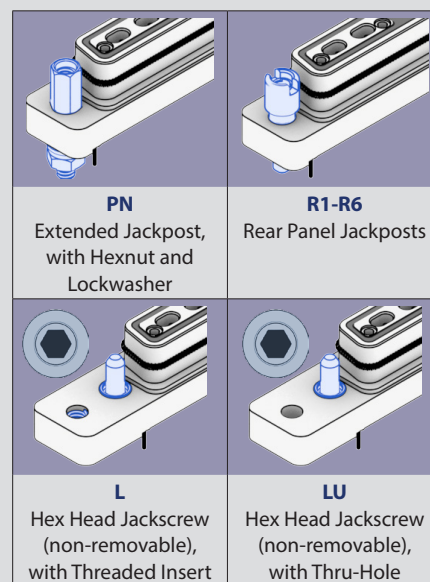

MICRO-D VERSALINK CONNECTORS

# "ZERO-CROSSTALK" M83513 Micro-D VersaLink™ Connectors



## GVLMS-BS, Board Mount Straight, Shielded Connector

MICRO-D VERSALINK CONNECTORS

### GVLMS-BS STRAIGHT PLUG CONNECTOR

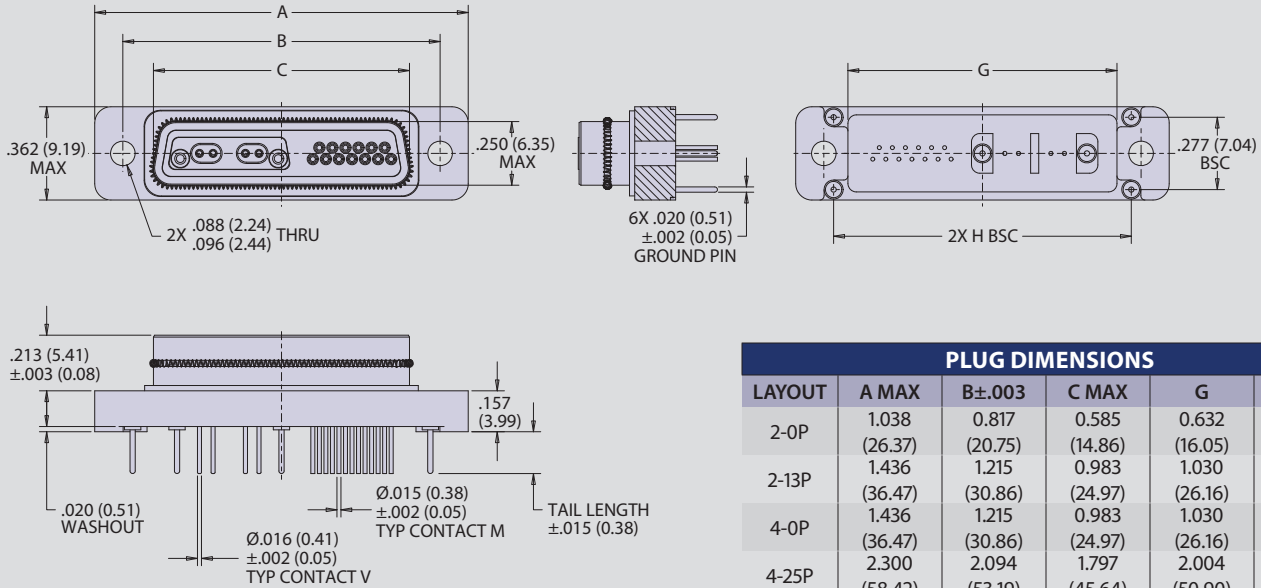

PLUG DIMENSIONS					
LAYOUT	A MAX	B±.003	C MAX	G	H BSC
2-0P	1.038	0.817	0.585	0.632	0.742
	(26.37)	(20.75)	(14.86)	(16.05)	(18.85)
2-13P	1.436	1.215	0.983	1.030	1.140
	(36.47)	(30.86)	(24.97)	(26.16)	(28.96)
4-0P	1.436	1.215	0.983	1.030	1.140
	(36.47)	(30.86)	(24.97)	(26.16)	(28.96)
4-25P	2.300	2.094	1.797	2.004	2.019
	(58.42)	(53.19)	(45.64)	(50.90)	(51.28)
8-0P	2.300	2.094	1.797	2.004	2.019
	(58.42)	(53.19)	(45.64)	(50.90)	(51.28)

### GVLMS-BS STRAIGHT RECEPTACLE CONNECTOR

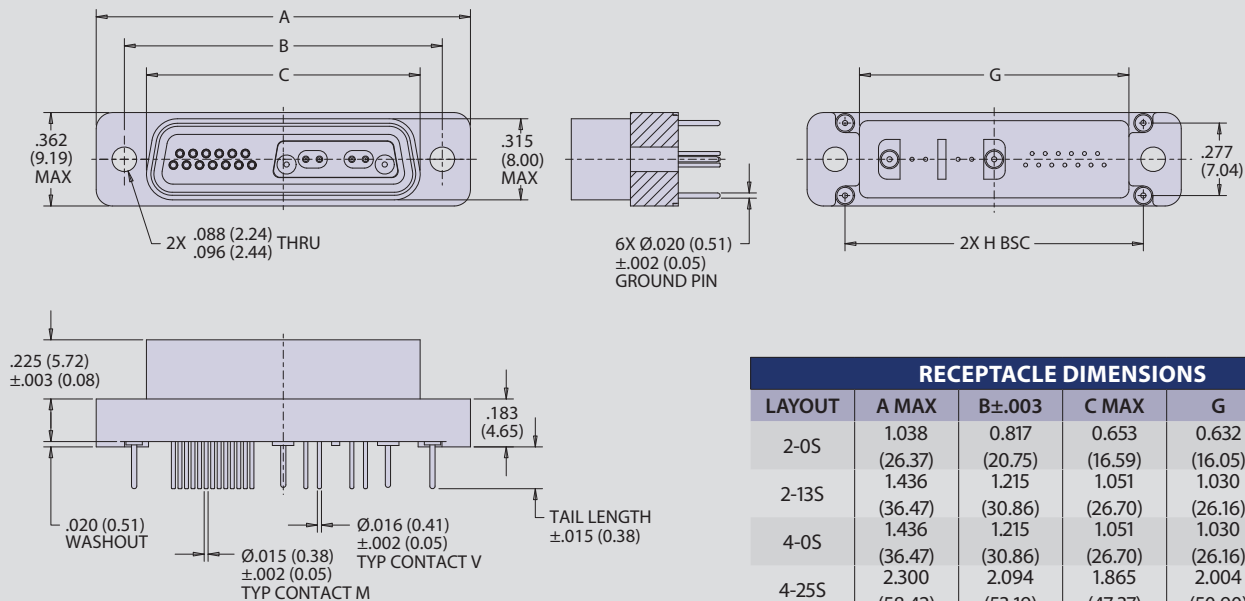

RECEPTACLE DIMENSIONS					
LAYOUT	A MAX	B±.003	C MAX	G	H BSC
2-0S	1.038	0.817	0.653	0.632	0.742
	(26.37)	(20.75)	(16.59)	(16.05)	(18.85)
2-13S	1.436	1.215	1.051	1.030	1.140
	(36.47)	(30.86)	(26.70)	(26.16)	(28.96)
4-0S	1.436	1.215	1.051	1.030	1.140
	(36.47)	(30.86)	(26.70)	(26.16)	(28.96)
4-25S	2.300	2.094	1.865	2.004	2.019
	(58.42)	(53.19)	(47.37)	(50.90)	(51.28)
8-0S	2.300	2.094	1.865	2.004	2.019
	(58.42)	(53.19)	(47.37)	(50.90)	(51.28)

# "ZERO-CROSSTALK" M83513 Micro-D VersaLink™ Connectors



## GVLMS-1000: GVLMS-BS, Board Mount Straight, Shielded Connector PCB Footprints

MICRO-D VERSALINK CONNECTORS

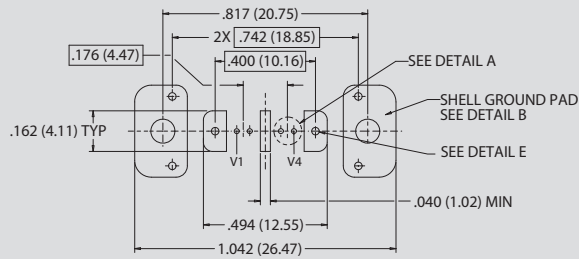

**Plug Layout 2-0 For PN and R1-R6 Hardware**

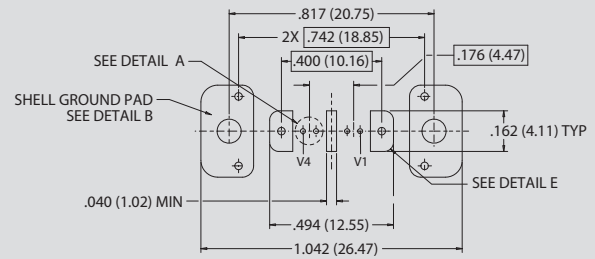

**Receptacle Layout 2-0 For PN and R1-R6 Hardware**

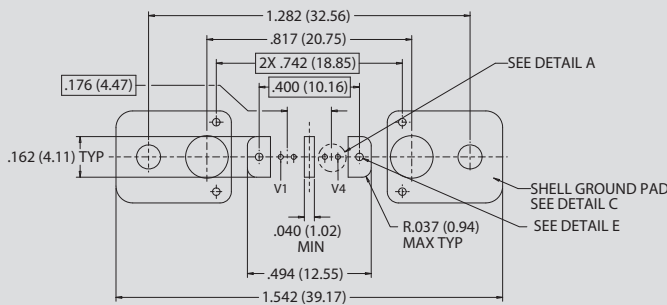

**Plug Layout 2-0 For L/LU Hardware**

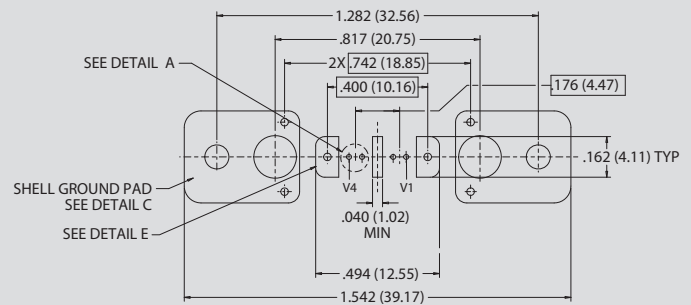

**Receptacle Layout 2-0 For L/LU Hardware**

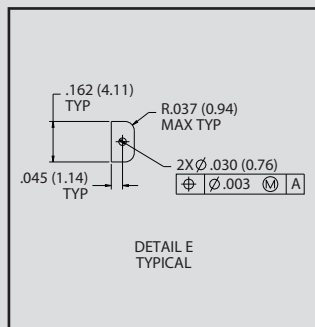
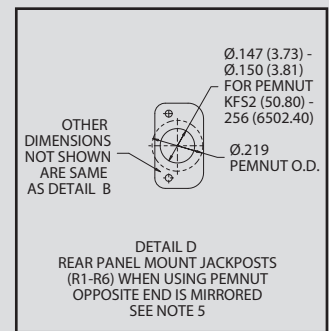
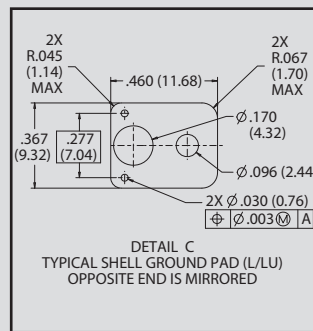
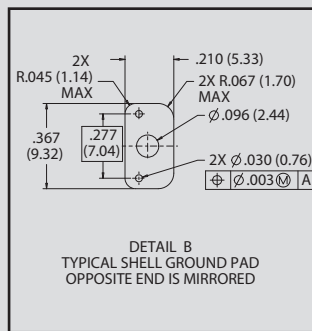
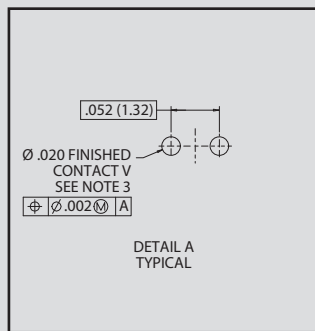

### NOTES

1. Patterns shown are for connector mounting side of PCB
2. Reference GVLMS-BS for connector details.
3. Reference application notes AN0005 for optimal performance
4. Pennuts are the recommended solution for rear mount hardware, see detail "D". When using loose nuts to secure to panel, use the same shell ground pad as shown in detail "B".

# "ZERO-CROSSTALK" M83513 Micro-D VersaLink™ Connectors



## GVLMS-1000: GVLMS-BS, Board Mount Straight, Shielded Connector PCB Footprints

MICRO-D VERSALINK CONNECTORS

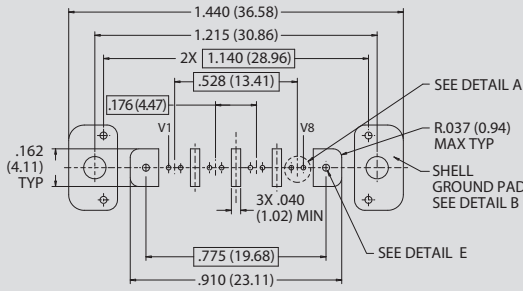

**Plug Layout 4-0 For PN and R1-R6 Hardware**

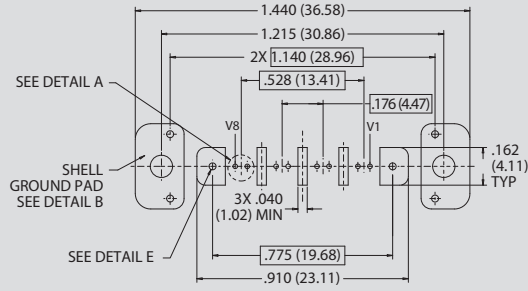

**Receptacle Layout 4-0 For PN and R1-R6 Hardware**

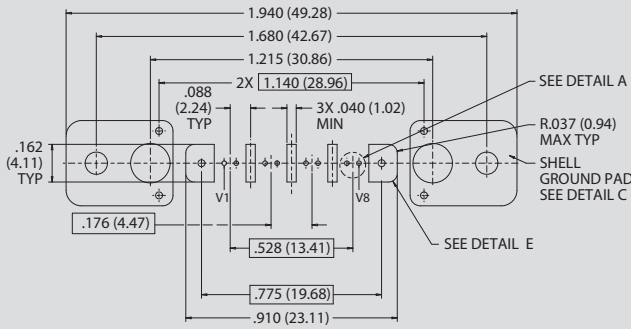

**Plug Layout 4-0 For L/LU Hardware**

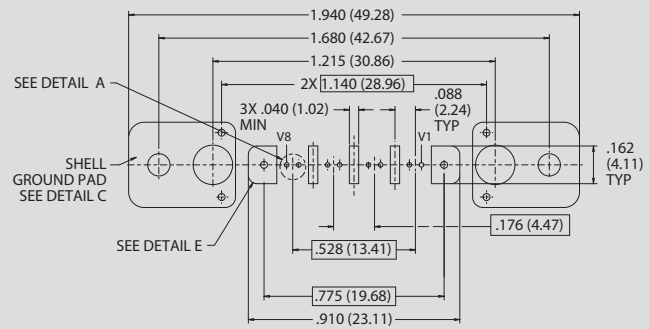

**Receptacle Layout 4-0 For L/LU Hardware**

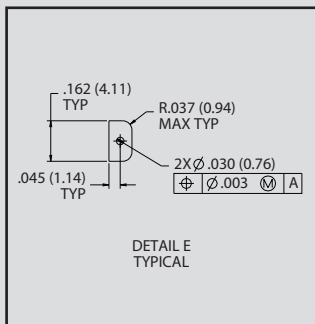
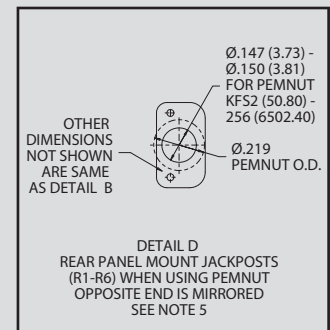
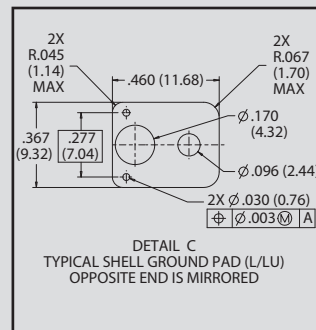
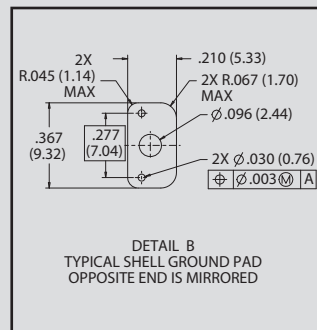
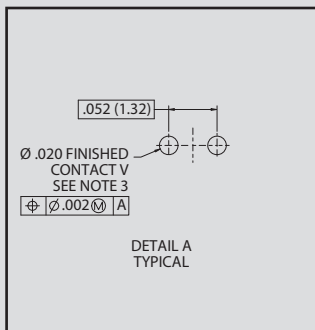

### NOTES

1. Patterns shown are for connector mounting side of PCB,
2. Reference GVLMS-BS for connector details.
3. Reference application notes AN0005 for optimal performance
4. Pemnuts are the recommended solution for rear mount hardware, see detail "D". When using loose nuts to secure to panel, use the same shell ground pad as shown in detail "B".

# "ZERO-CROSSTALK" M83513 Micro-D VersaLink™ Connectors



## GVLMS-1000: GVLMS-BS, Board Mount Straight, Shielded Connector PCB Footprints

MICRO-D VERSALINK CONNECTORS

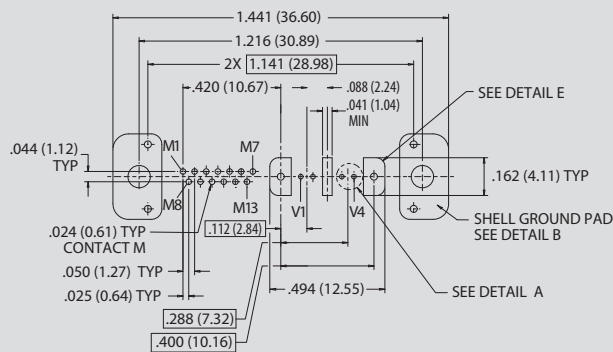

**Plug Layout 2-13  
For PN and R1-R6 Hardware**

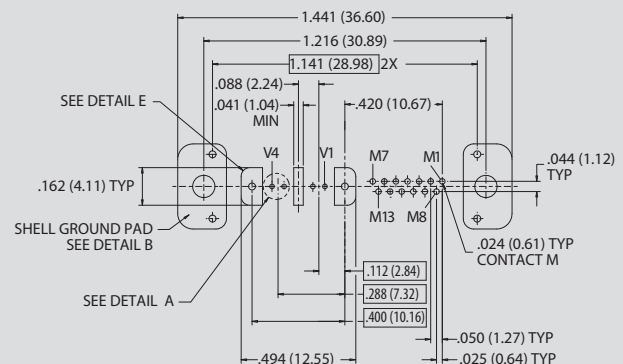

**Receptacle Layout 2-13  
For PN and R1-R6 Hardware**

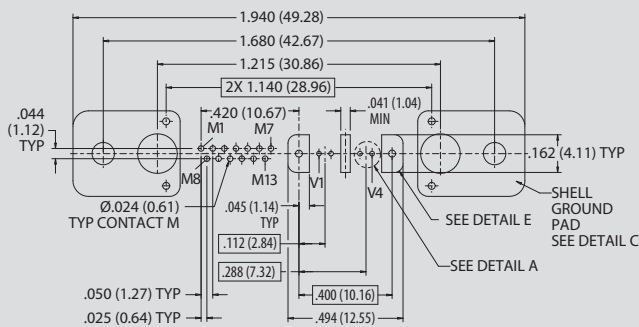

**Plug Layout 2-13  
For L/LU Hardware**

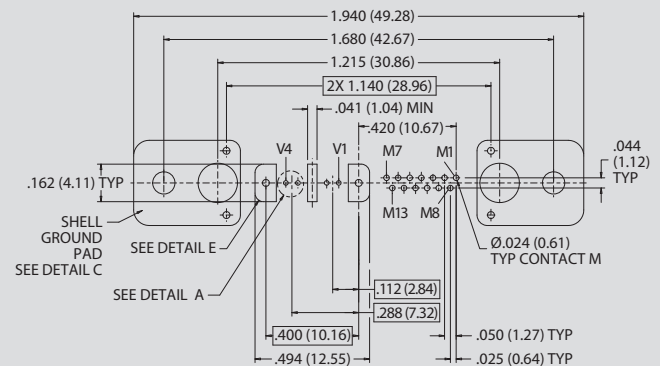

**Receptacle Layout 2-13  
For L/LU Hardware**

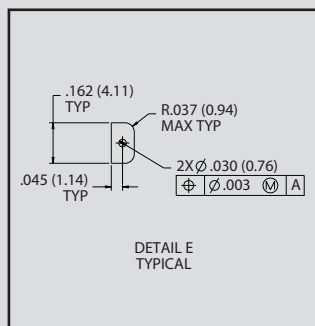
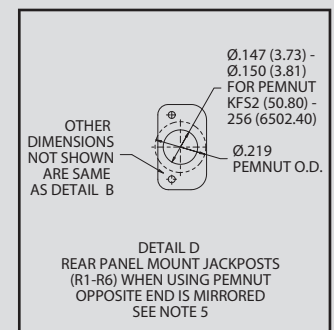
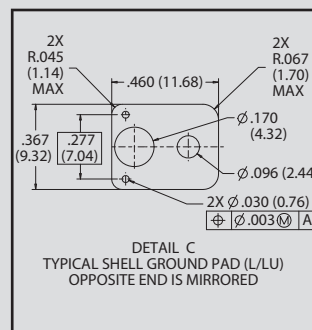
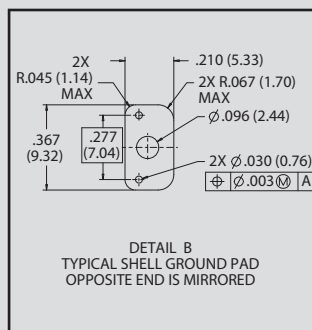
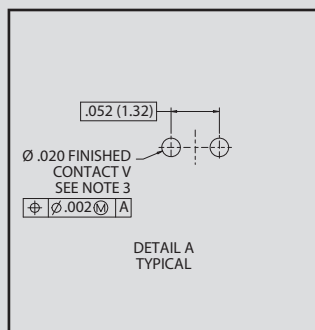

### NOTES

1. Patterns shown are for connector mounting side of PCB
2. Reference GVLMS-BS for connector details.
3. Reference application notes AN0005 for optimal performance
4. Pennuts are the recommended solution for rear mount hardware, see detail "D". When using loose nuts to secure to panel, use the same shell ground pad as shown in detail "B".

# "ZERO-CROSSTALK" M83513 Micro-D VersaLink™ Connectors



## GVLMS-1000: GVLMS-BS, Board Mount Straight, Shielded Connector PCB Footprints

MICRO-D VERSALINK CONNECTORS

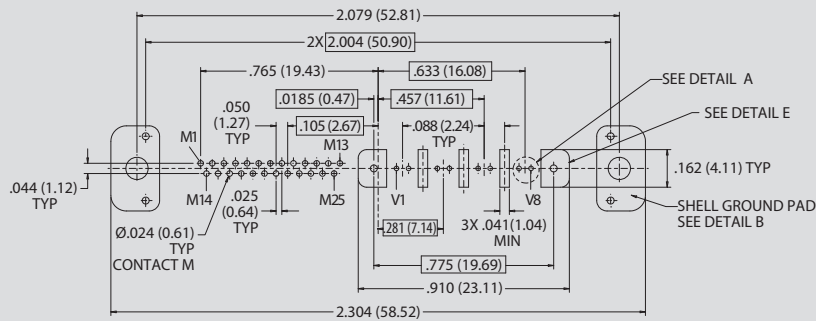

**Plug Layout 4-25 For PN and R1-R6 Hardware**

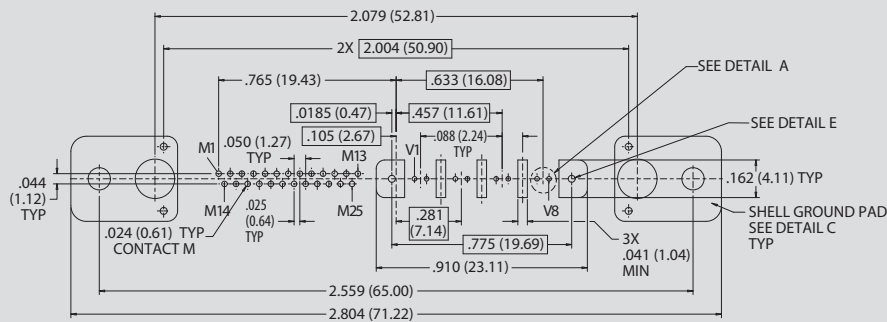

**Plug Layout 4-25 For L/LU Hardware**

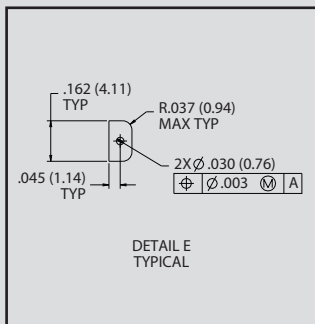
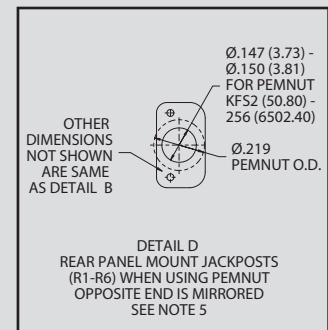
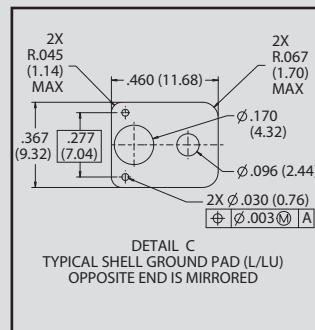
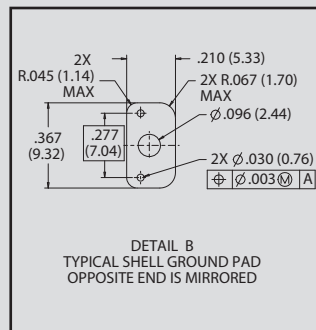
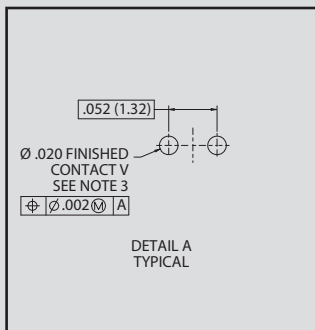

### NOTES

1. Patterns shown are for connector mounting side of PCB,
2. Reference GVLMS-BS for connector details.
3. Reference application notes AN0005 for optimal performance
4. Pemnuts are the recommended solution for rear mount hardware, see detail "D". When using loose nuts to secure to panel, use the same shell ground pad as shown in detail "B".

# "ZERO-CROSSTALK" M83513 Micro-D VersaLink™ Connectors



## GVLMS-1000: GVLMS-BS, Board Mount Straight, Shielded Connector PCB Footprints

MICRO-D VERSALINK CONNECTORS

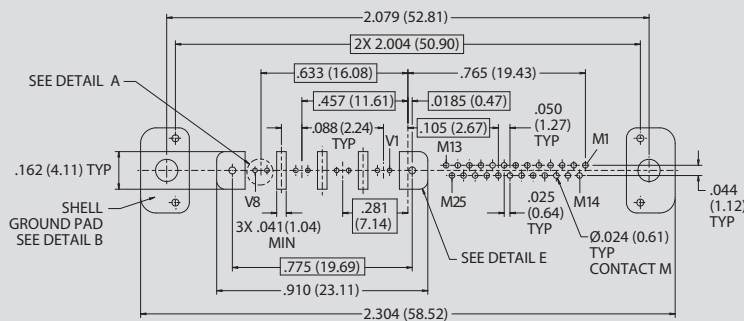

**Receptacle Layout 4-25 For PN and R1-R6 Hardware**

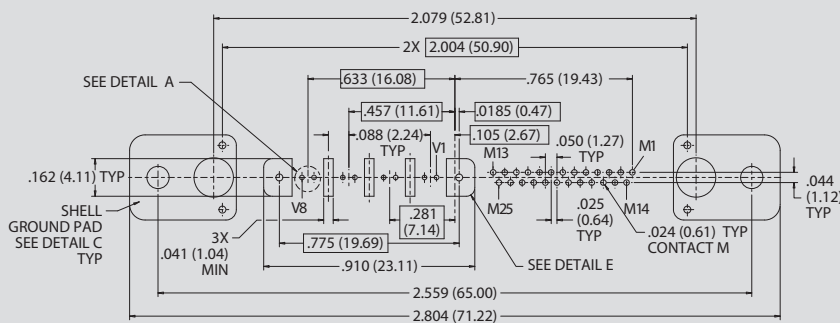

**Receptacle Layout 4-25 For L/LU Hardware**

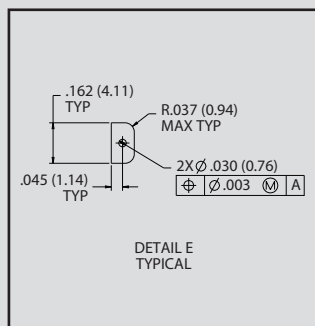
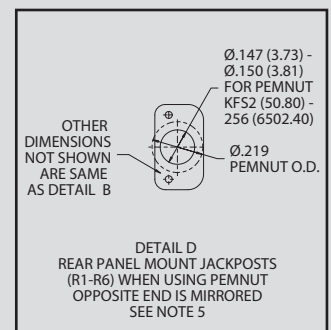
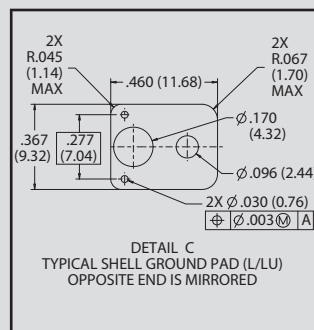
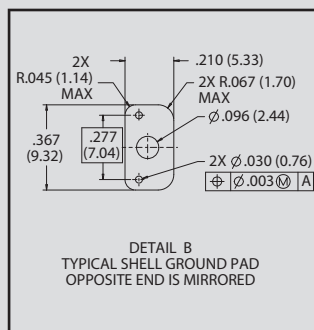
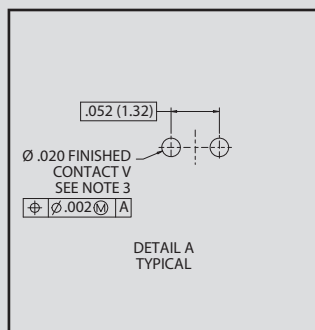

### NOTES

1. Patterns shown are for connector mounting side of PCB,
2. Reference GVLMS-BS for connector details.
3. Reference application notes AN0005 for optimal performance
4. Pennuts are the recommended solution for rear mount hardware, see detail "D". When using loose nuts to secure to panel, use the same shell ground pad as shown in detail "B".



# "ZERO-CROSSTALK" M83513 Micro-D VersaLink™ Connectors



## GVLMS-1000: GVLMS-BS, Board Mount Straight, Shielded Connector PCB Footprints

MICRO-D VERSALINK CONNECTORS

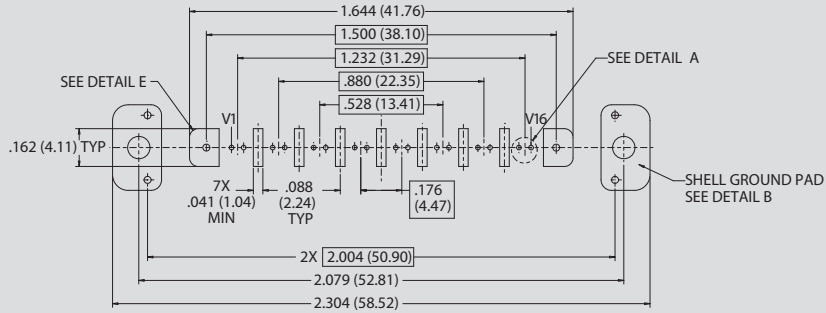

**Plug Layout 8-0 For PN and R1-R6 Hardware**

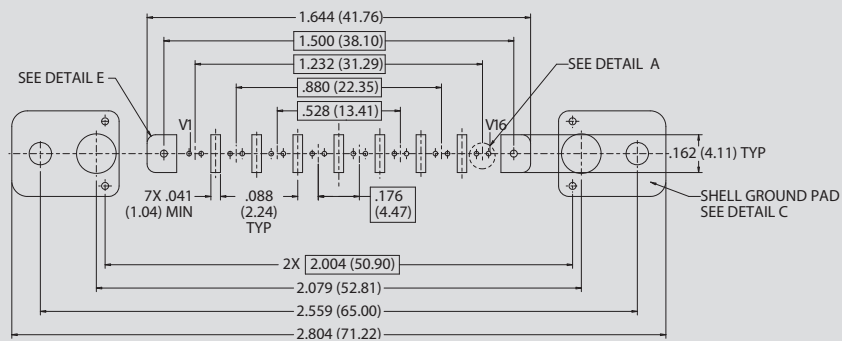

**Plug Layout 8-0 For L/LU Hardware**

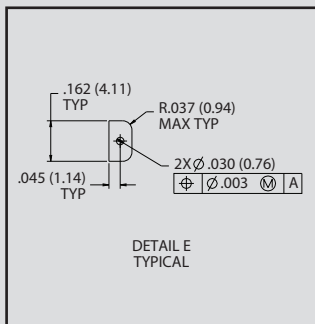
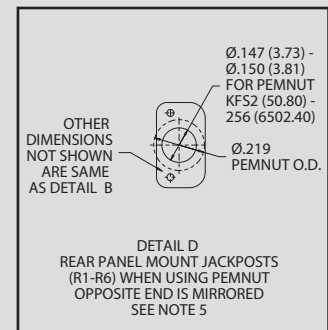
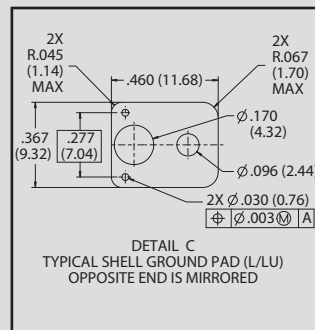
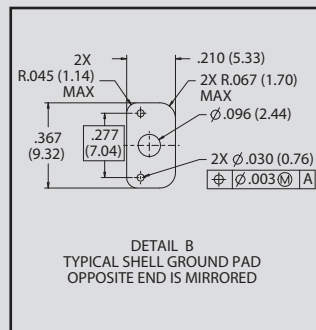
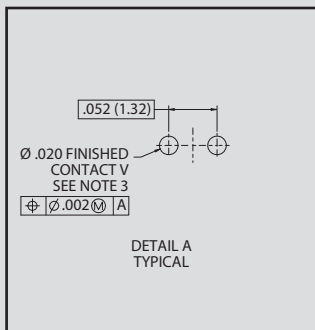

### NOTES

1. Patterns shown are for connector mounting side of PCB,
2. Reference GVLMS-BS for connector details.
3. Reference application notes AN0005 for optimal performance
4. Pemnuts are the recommended solution for rear mount hardware, see detail "D". When using loose nuts to secure to panel, use the same shell ground pad as shown in detail "B".



# "ZERO-CROSSTALK" M83513 Micro-D VersaLink™ Connectors



## GVLMS-1000: GVLMS-BS, Board Mount Straight, Shielded Connector PCB Footprints

MICRO-D VERSALINK CONNECTORS

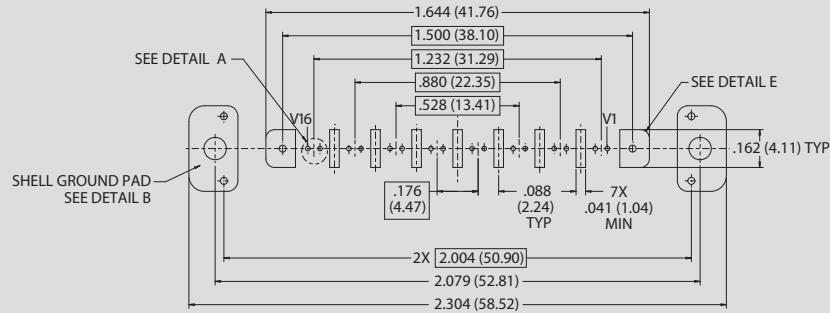

**Receptacle Layout 8-0 for PN and R1-R6 Hardware**

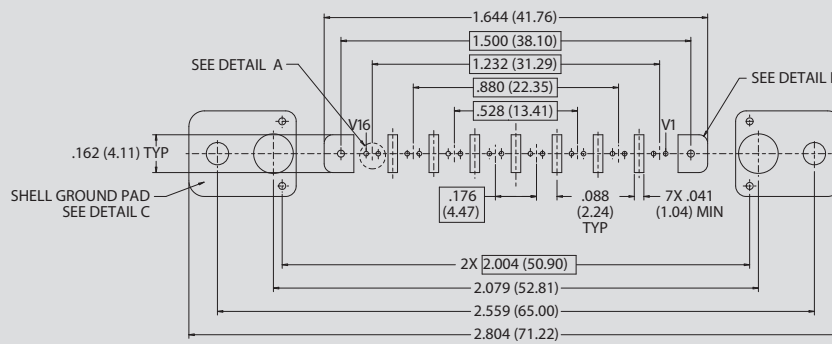

**Receptacle Layout 8-0 for L/LU Hardware**

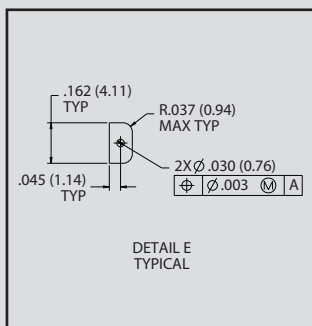
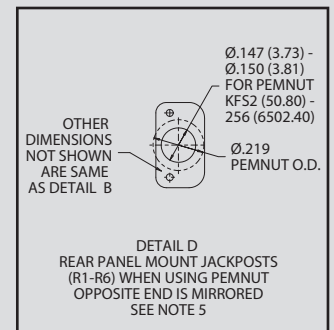
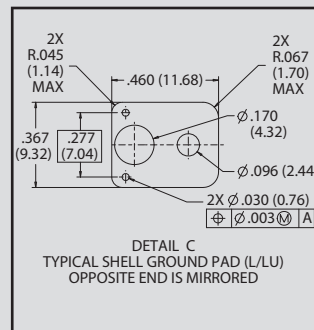
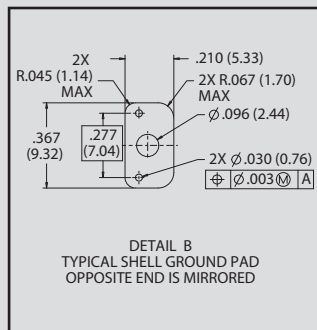
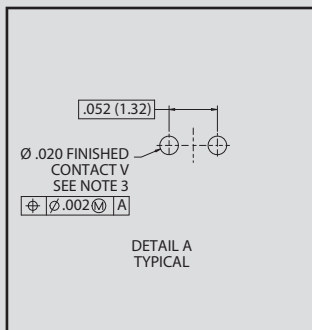

### NOTES

1. Patterns shown are for connector mounting side of PCB,
2. Reference GVLMS-BS for connector details.
3. Reference application notes AN0005 for optimal performance
4. Pennuts are the recommended solution for rear mount hardware, see detail "D". When using loose nuts to secure to panel, use the same shell ground pad as shown in detail "B".